

Elekta Neuromag

---

# **Sensor Tuner**

## **User's Guide**

**Software Version 3.0 for  
Elekta Neuromag**

March 2005

---

This document contains copyrighted and possibly confidential information and is intended for the exclusive use of customers having Neuromag products and authorized representatives of Elekta Neuromag Oy. Disclosure to others or other use is strictly prohibited without the express written authorization of Elekta Neuromag Oy.

Elekta Neuromag Oy reserves the right to make changes in the specifications or data shown herein at any time without notice or obligation.

Elekta Neuromag Oy makes no warranty of any kind with regard to this document and the related software, including but not limited to, the implied warranties of merchantability and fitness for a particular purpose. Elekta Neuromag Oy shall not be liable for errors contained herein or direct, indirect, incidental or consequential damages in connection with the furnishing, performance, or use of this material and software.

Elekta Neuromag, Vectorview and Neuromag System are trade marks of Elekta Neuromag Oy, UNIX is a trademark of UNIX System Laboratories, Inc., and Motif is a trademark of Open Software Foundation, Inc.

Editor: Matti Kajola

© 2001-2005 Elekta Neuromag Oy. All rights reserved.  
Printed in Finland.

Printing History	Neuromag p/n	Software	Date
1st edition	NM21283A	tune_vv 3.0.x	2001-12-27
2st edition	NM21283A-A	tune_vv 3.0.x	2005-03-13



---

# Contents

Introduction	1
--------------	---

## Part 1 Basic Usage

<b>Chapter 1</b>	<b>User interface basics</b>	<b>5</b>
1.1	Using menus	5
1.2	Using text fields	5
1.3	Using file selection boxes	6
<b>Chapter 2</b>	<b>Getting started</b>	<b>9</b>
2.1	Beginning a session	9
2.2	Using online HELP	10
2.3	Ending a session	10
<b>Chapter 3</b>	<b>Basic tuning operations</b>	<b>11</b>
3.1	Measuring the sensor noise level	11
3.2	Fine tuning	12
3.3	Resetting channels	13
3.4	Heating sensors	13
3.5	About saving and loading settings	14
3.6	Noise display	15
<b>Chapter 4</b>	<b>Troubleshooting</b>	<b>17</b>
4.1	Basic checks	17
4.2	Viewing noise history of a channel	17
4.3	Tuning selected channels	18
<b>Chapter 5</b>	<b>Description of the menus</b>	<b>21</b>
5.1	File Menu	21
5.2	Parameters Menu	21
5.3	Commands Menu	22
5.4	Search Menu	22
5.5	View Menu	23
5.6	Help Menu	23

---

## Part 2 Sensor operation principles

<b>Chapter 6 Principles of SQUID operation</b>	<b>27</b>
6.1 Operation of a SQUID magnetometer .....	27
6.2 SQUID electronics of Vectorview .....	29
6.3 Optimal point of operation .....	31
<b>Chapter 7 Manual tuning</b>	<b>33</b>
7.1 Need for manual tuning .....	33
7.2 Tools for manual tuning .....	33
7.3 Measuring flux to current curves using Squiddler .....	34
7.4 Measuring flux to current curves using Tuner .....	34
7.5 Measuring noise level .....	34
7.6 Manual tuning procedure .....	35
7.7 Typical sensor problems .....	39

## Part 3 Advanced features

<b>Chapter 8 Basic measurements</b>	<b>43</b>
8.1 Setting the expert level .....	43
8.2 Selecting and running jobs .....	44
8.3 Measurement parameters .....	45
8.4 View modes .....	46
8.5 I-Phi measurement .....	46
8.6 Noise measurement .....	47
8.7 FFT measurement .....	49
8.8 Signal .....	50
<b>Chapter 9 Tuning procedures</b>	<b>51</b>
9.1 Noise level based tuning .....	51
9.2 Tuning based on characteristics .....	52
9.3 Manual tuning .....	52
<b>Chapter 10 Measuring characteristics</b>	<b>53</b>
10.1 Operating point parameters .....	53
10.2 Measuring derivative information .....	54
10.3 Measuring and using current-voltage characteristics .....	54
10.4 Measuring gate curves .....	55
<b>Chapter 11 Miscellaneous</b>	<b>56</b>
11.1 Searching channels .....	56

---

11.2 Loading and saving in special cases .....	56
11.3 Marking broken channels .....	57
11.4 Reverting operating points .....	57
11.5 Creating start-up files .....	57
11.6 Updating the power-up settings .....	58
11.7 Synchronizing Janitor .....	59
11.8 Using SSP .....	59
<b>Chapter 12 Description of the menus</b>	<b>61</b>
<hr/>	
12.1 File Menu .....	61
12.2 Job Menu .....	62
12.3 Parameters Menu .....	63
12.4 Commands Menu .....	64
12.5 Search Menu .....	65
12.6 View Menu .....	65
12.7 Help Menu .....	67
<b>Appendix A Command line options</b>	<b>68</b>
<hr/>	
<b>Appendix B Parameters</b>	<b>69</b>
<hr/>	
<b>Appendix C Revision history</b>	<b>76</b>
<hr/>	

---

---

# Introduction

This manual has two functions. It is at the same time the user's manual of the sensor tuning program and also a manual describing the operation principles of Vectorview™ sensor hardware. Detailed descriptions about the SQUID sensor system, electronics, and tuning principles, are given in addition to the description of the tuning program.

The SQUID tuner program `tune_vv`, is a versatile tool that can be used in maintenance of Vectorview™ measurement system. It facilitates the tuning and monitoring of the performance of the sensor electronics.

The key features provided by the program are:

- Measuring white noise level.
- Automatic fine tuning of the noise level.
- Adjusting sensor operating point manually.
- Measuring several characteristic curves of the sensors.
- Manual heating of single or all sensors.

The functionality of the program depends on the *expert level* being used. The lowest level 0 allows noise measurements and automatic fine tuning of the system. The expert level 1 allows more complicated measurements and setting of various parameters affecting the program. Using the features in level 1 requires understanding of the operation of the sensor system, and is intended to be used by service personnel.

This manual is divided in three parts. The first one describes how to tune the system automatically using the SQUID tuning program. This is a everyday operation, and reading of this part is recommended for all users. All expert level 0 operations are explained.

The second part explains the operating principles of a SQUID sensor and electronics. It also contains a detailed description how the sensors are tuned manually. This information is essential for the maintenance personnel and for understanding advanced features of the tuning program.

The third part describes advanced features of the tuning program. These are available when the expert level is set to 1, and are normally used only by the maintenance personnel.





# PART 1

## Basic Usage

---

---

This part describes the basic usage of the SQUID tuning program. It contains information about the functionality available in the lowest expert level 0. This allows measuring white noise level of all channels and automatic fine tuning. Reading of this part is recommended for all users of a Vectorview system.



---

## CHAPTER 1 **User interface basics**

---

This chapter explains the notation conventions used in this manual and the basics of the user interface manipulation. If you are familiar with the Motif interface, you may want to skip the rest of this chapter. The description of the interface given here is not intended to be complete, but rather to give enough of information to let a novice user to operate the program. For more information about the general manipulation of the operating system interface, refer to “User’s Guide” of Common Desktop Environment.

---

### **1.1 Using menus**

---

On the top of the main window of the program lies a horizontal bar containing so called menus. Each one is represented by its name. When the name is clicked with the mouse button 1 (usually the leftmost button), a stack of buttons appears. This stack of buttons is called a menu. You can initiate different kinds of operations by clicking corresponding button in a menu. When a button within the menu is pressed, and the mouse button is released, the corresponding action will be executed, and the menu disappears.

You may also activate a menu button by pressing the mouse button on the name of the menu, holding the button down and dragging it on top of the desired button. The action is now executed when the button is released on the menu item. If you pop up a menu accidentally, you can cancel the operation by releasing the mouse button when cursor is outside the menu, or if you clicked the name, by clicking somewhere outside the menu.

Some menus contain so called submenus. They are connected to menu buttons whose activation pops up yet another menu. The submenu itself is used just similar fashion as a normal menu. Submenus are denoted by a small triangle on the left edge of a menu button.

---

### **1.2 Using text fields**

---

Several user interface elements use so called text fields, or text boxes. This is a rectangle that contains some editable text inside.

To enter some new text into an empty field, click the rectangle to get the active text insertion point (so called text focus) into the desired text field. Then use keyboard to enter whatever text that is needed. If the text editor has multiple lines, use return key to start a new line. Notice that in single line text fields, pressing the return key may cause some execution to occur. In several dialogs it is equivalent of pressing the default button of the dialog.

If you need to alter all or some text in a text field, select first the text to be altered by pressing the mouse button 1 on the starting point of the text to be replaced, and dragging the cursor to the end point of the text to be selected, and then releasing the button. The selected text should now have different background color that rest of the text. Then simply type in the new text. When you press the first character of the new text, the old selected text will disappear.

Some text can be removed from a text field by first selecting it as described above, and then pressing delete key. Note that the last selected piece of text is also copied into the clipboard of the program. The current selection in the clipboard can be “pasted” in any text field by clicking the insertion point with mouse button 2. Selecting some text by button 1 and pasting it in some other place by pressing button 2 saves often a lot of time compared to entering the same text from keyboard. Copying long numbers is usually also more reliable than entering them manually.

### 1.3 Using file selection boxes

In several phases of the analysis one must select a file to be loaded or processed. In most cases user can do this selection using a file selection box dialog. The figure on the left shows an example dialog.



On the top there is a field that contains a directory specification along with a file mask. This specification defines the directory from which a file can be selected, and the subset of files within this directory that are shown as possible choices. If the mask part after the last slash in specification is character \*, all files in the directory are shown. If the mask contains other characters, the file names show must contain the same pattern. For example specification `/neuro/dacq/tuning/*.tnp` would select all files in directory `/neuro/newdata/test` that end to string `".tnp"`.

Below the directory specification there are two selection boxes. The left one lists all subdirectories to the directory specified above. You can change the currently viewed directory easily by double clicking a directory name in this list. The right list contains all the files matching the directory specification. Note that the parent directory is noted by filename `".."` (two dots) in these lists.

Below the lists there is a text field that shows the currently selected file. If you must create a new file that does not exist yet, you can enter the new name in this field and press ok button. For details of editing text fields see “Using text fields” on page 5.

To select a file that already exists, double click the name of the file in the right selection box. You may also select the file name by clicking it once, and then pressing the ok button.

If you need to cancel the ongoing selection, press the cancel button on the bottom of the dialog.



## CHAPTER 2 Getting started

This chapter gives you an overview of the program, explains how to start and stop it and provides some basic aspects that you need to know.

### 2.1 Beginning a session

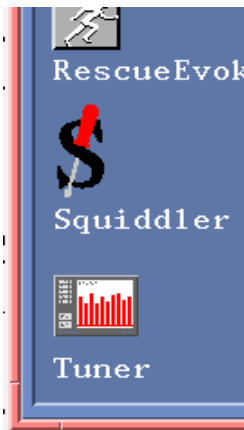

The tuner program can be started in three ways:

- Selecting the **Tuner...** button in the **Tools** menu of the acquisition program. Measurements using acquisition program should be stopped before starting the tuner. See “*Data acquisition User’s Manual*” for details of the acquisition program.
- Using the graphical user interface of the operating system by double clicking the tuner icon in “Maintenance” toolbox under the “MEG analysis” toolbox.
- Giving a suitable command in UNIX shell. For the proper command and options, refer to Appendix A.

Only one tuning program should be running at any time. If the tuning program is already running on the same system, the new starting program shows an question dialog warning about the already running program. In such a case you should answer **OK** to stop the new one and find out who is running the program. It is possible that you get this message even if there is no other instance of the program running, for example if the program was killed or it died unexpectedly. If you are sure that there is no other copy running you can go on using the program by responding with **Cancel** button.

After starting the program, a user interface similar to Figure 2.1 appears. On the top of the window is a menu bar that allows access to several operations and parameter settings. Major part of the window area is taken by a graphics area which is used to show the results of current operation. On the left are controls to show and alter manually the SQUID working point parameters and two large buttons that are used to initiate and stop operations. These buttons will be called “start button” and “stop button” throughout the manual. The labels on these buttons change depending on the situation. In the bottom of the window is a status display area and controls to alter graphics display scales.

The status display area is divided in four regions described here from left to right:

- The leftmost small icons show the state of the acquisition.
- Area showing current helium level in the dewar.
- Status message area which shows information about ongoing activities.
- Information area showing variable user data like cursor position.
- Scale controls of the graphics display.

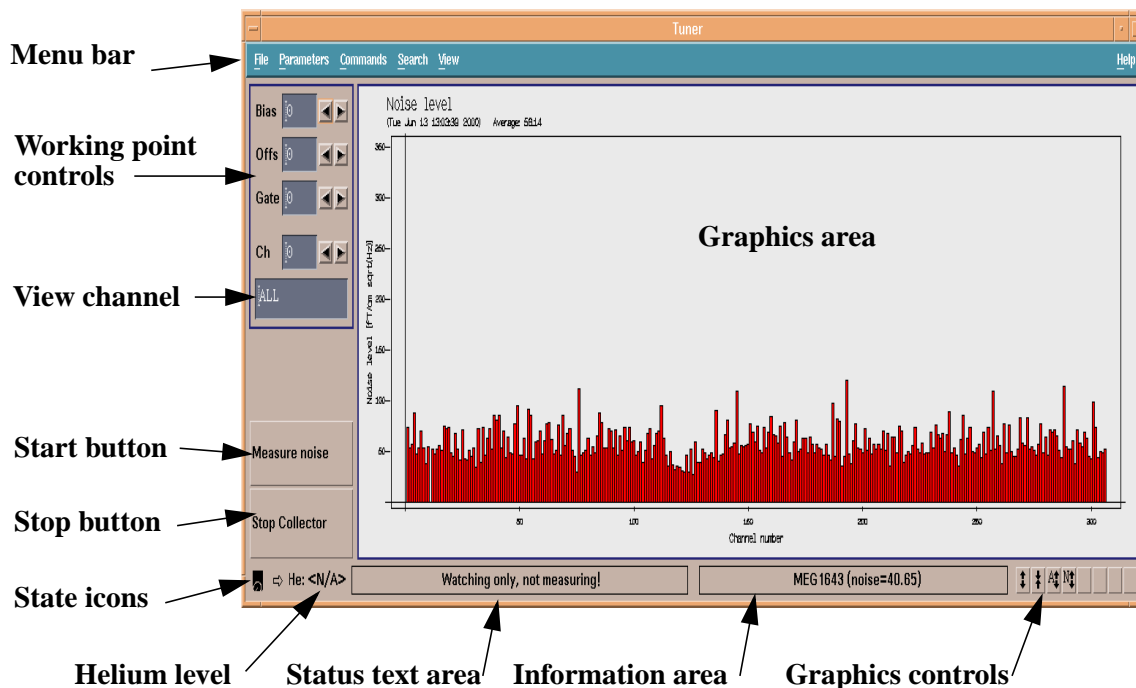

Figure 2.1 Main window of the SQUID tuning program

## 2.2 Using online HELP

The **Help** menu contains currently only a button which shows the version information about the program. No online help is currently available.

## 2.3 Ending a session

To exit the program, select **Exit** from the **File** menu. This menu is inactive (gray) during active measurements, so if the menu is unavailable you must stop the ongoing measurement by pressing the "stop button". It is recommended that you exit the program after checking the noise levels or tuning before starting a new acquisition.



---

## CHAPTER 3 Basic tuning operations

---

This chapter explains how to measure white noise level of the sensors, automatic fine tuning, and heating of the sensors.

### 3.1 Measuring the sensor noise level

---

The tuner program can be used to check the white noise level of all the sensors. This can be done before the measurements to check that all channels are working properly.

To measure white noise levels using Tuner:

1. Stop any ongoing acquisition by pressing stop button of the acquisition program, and wait for the measurement to stop.
2. Start the tuning program (if not running yet). See “Beginning a session” on page 9.
3. Press the large “Measure noise” button on the left.

---

**Warning:** If there was a measurement running when the tuner was started, the start button is gray, and no tuner measurements can be initiated. In this case, one must exit the tuner, stop the normal acquisition measurement, and then restart the tuner again.

---

---

**Warning:** Acquisition program can not perform measurements if the tuner is accessing the measurement system. To enable measurements, press stop button to stop current operation, and then another time to release the collector (software part responsible for delivering the magnetometer data). It is recommended that you then exit the tuning program, even though that is not necessary to perform normal acquisition.

---

The program now starts measuring the noise level of the system. The noise level of all channels is shown on a bar display in the display area. Normally all bars should be red and display value between 2 to 5  $\text{fT}/\sqrt{\text{Hz}}$  ( $\text{fT}/(\text{cm}\sqrt{\text{Hz}})$  for gradiometers). Small negative bars indicate channels that are saturated and probably are not operating in flux locked mode (not functioning properly). Note that the colors can be adjusted personally. The above description refers to default colors.

If the noise values look good you can press the “stop button”, exit the program, and go on measuring with the acquisition program. If not, proceed to tune the channels. This is explained in the next section.

---

## 3.2 Fine tuning

---

Normally the program is used to tune slight offsets from a good operating point that is set after the installation of the system or thermal cycling. This is referred as fine tuning.

Before tuning one should measure the noise level. See “Measuring the sensor noise level” on page 11. If it is abnormally high, check that the door of the shielded room is closed. If the noise still looks very high, or some channels are saturated (small black bars appear in the display), try heating the noisy channels. See “Heating sensors” on page 13. If the overall noise level is very high, you probably need to load suitable tuning settings from a file before doing the fine tuning. See “About saving and loading settings” on page 14. Contact your administrator to find out the correct tuning file.

When the channels seem to work properly, but the noise level is higher than normally, running the auto-tuning routine of the tuning program should be able to fine tune the noise levels to normal.

To tune sensors automatically:

1. Start a noise level measurement.
2. Press the “start button” again (the same button that was used to start the noise measurement). The button should now have text **Tune** on it.
3. Wait until the tuning has obtained good noise values. (Or, hopefully not, failed to tune the noise.) The tuning does not stop automatically. It continues until it is explicitly stopped.
4. Press **Stop tuning** button.
5. Press **Stop collector** button (the same stop button as before which now has different text on it), to release the acquisition system for normal measurements.

---

**Warning:** All measurements should be made with the doors of the shielded room closed.

---

---

**Warning:** Heat single noisy channels before tuning. Tuning may success even with flux trapped SQUID but then the tuning is off when the sensor is later returned to its normal state.

---

---

**Warning:** Tuning for excessively long times (>5 min.) does not make the tuning better. Instead, if the noise level is limited by something else than SQUID noise, the tuning settings may drift to unstable values.

---

### 3.3 Resetting channels

---

The SQUID sensors are operated in so called flux locked mode. See “SQUID electronics of Vectorview” on page 29. In some situations the electronics is not capable following the signal and the output gets saturated. This can be due to very strong signals (e.g. environmental low frequency drift) or sharp transients. To get the sensor working again, the integrator in the feed back loop and the zeroing mechanism (high pass filter), need to be reset. Saturated channels that need to be reset are represented as small negative bars in the noise display.

To reset all channels:

1. Select **Commands > Reset electronics** from the menus.

### 3.4 Heating sensors

---

The coils and the SQUIDs in a sensor unit contain very thin superconducting film. Sometimes when the sensor is exposed to strong (relative to the signals measured) magnetic field, these films “trap” magnetic flux. Strong magnetic field can penetrate the film destroying the superconductivity from a small patch of the film so that the field can go through it. Typically the impurities in the films cause these “holes” to stick at some fixed position, thus this phenomenon is often called “flux trapping”.

The flux trapping in the sensor coils is not problematic if the flux really stays in place. Unfortunately it is quite common that the trapped flux moves between e.g. two points. Since the flux pinned into the film is always strong, even a very small movement cause severe jumping in the sensor signal.

If the flux trapping occurs so that the flux penetrates the Josephson junctions in the SQUID, the sensor ceases to work. If the pinning point is in near neighborhood of the junctions, the extra field leaking through the junctions cause the modulation depth of the SQUID to diminish. This can manifest itself as increased noise or, if the effect is reasonably small, as moving of the optimal operating point (bias, offset, and gate voltages) to somewhat different values.

The magnetic flux in the thin films of the sensor can be removed by heating the sensor above the critical temperature of the films, and then letting it cool down again. The sensors in Vectorview are equipped with small

heating resistors, so that this can be easily achieved by feeding a suitable current pulse into the resistor. Note that each sensor unit contains three SQUIDs, so three channels are always heated together.

To heat a single sensor that contains a particular channel:

1. Select the view channel by entering the channel name to the selection box of the working point controls at the left side of the display area. Press return and check that the name of the channel appear on the top of the display.
2. Select **Command > Heat sensor** from the menus.

To heat all the sensors:

1. Select **Command > Heat all sensors** from the menus.

If you are making a noise measurement, you need also reset the electronics after heating. See “Resetting channels” on page 13.

---

### 3.5 About saving and loading settings

---

Tuning settings can be saved on disk and loaded back to magnetometer later on. Recommended practice is that there should be two or three standard settings files that contain carefully made good values for normal usage and some special situations like using the device just after helium filling or when the helium level is very low. In normal conditions one good setting file should be enough.

If the automatic fine tuning of the system does not succeed, one should try first to heat bad channels and if that is not enough, load a well known tuning setting file. If this tuning still fails, contact your system administrator to find out what has changed.

It is not recommended that the tuning settings are saved after each fine tuning and then reloaded when tuning is needed next time, since then the tuning settings files tend to “drift” and nobody really knows how the system should perform when some particular file is used. It is usually better to have fixed files that are saved only by the administrative personnel so that the expected performance is known and possible changes in the system can be detected.

To load tuning settings into tuner and magnetometer:

1. Select **File > Load tunings** from the menu. A dialog will pop up.
2. If the file suggested by the dialog is the one you want to load, press **OK** to load the file. Otherwise press **Load other** to pop up an ordinary file selection box and use it to select the file you want to load. See “Using file selection boxes” on page 6.





To save tuning settings into a file:

1. Select **File > Save tunings** from the menu. A dialog will pop up.
2. If the file name suggested is the one into which you want to save the settings, press OK, if not, press **Save elsewhere**, and use the appearing file selection box to select the file.

If you get an error message “Could not get clean snapshot (bad params at ch <number>)”, this means that all parameters of the tuner are not set properly. However you can save the settings anyway if you just need to save the regular working point parameters. To get rid of this message, contact your administrator to set up the start-up files to contain all required information.

### 3.6 Noise display

The tuner displays normally bar diagram showing the noise level of all channels. During fine tuning this display shows the noise after each step. The default scale should be good in normal situations. If you need to change the y-scale of the display, use the control buttons in the lower right corner of the display. The buttons available are following:

	Make bars look bigger
	Make bars look smaller
	Autoscale bars heights
	Give y-scale numerically

**Table 3.1**

Note that the autoscale button is a toggle button. If you press it once, all following plots will be automatically scale and the scale varies from plot to plot. To fix the scale again press the button an another time. The autoscaling is also set off automatically if you press any other scaling button. To enter a numeric value to the scale, press the fourth button. The whole area will change to a text box where you can enter the scale you want to use. Pressing **RETURN** activates the new value and the icons are shown again.

If you see a bar indicating a noisy channel and you want to know which channel that is, move cursor over the bar and press the left button. The name and noise level at that channel is shown in the information area. See Figure 2.1 on page 10.

It is also possible to show the noise values as a histogram. To do that select **View > Noise histogram** from the menus. In the bar histogram gradiometer channels and magnetometer channels are shown separately. Gradiometers with red bars and magnetometers with blue bars (assuming default colors). The lower bar is always in front of the higher one, so no bars are hidden behind the others.

Histogram bin width and number of bins can be adjusted from the preferences dialog box. See Appendix B for meanings of the parameters.

---

## CHAPTER 4 Troubleshooting

---

This chapter describes how to deal with the most common problems with the sensors. For a more detailed description of the manual tuning and trouble shooting, see “Manual tuning” on page 33. Also some more advanced features available are explained including viewing the noise history during the tuning and how to tune only some specific channels.

---

### 4.1 Basic checks

---

If the noise level is very high before fine tuning, try following operations until the situation looks better:

- Check that the door of the shielded room is closed.
- Check that there is no strong source of disturbance inside the room, like a moving patient.
- Load a well known tuning file. See “About saving and loading settings” on page 14.
- Heat suspicious or all sensors. See “Heating sensors” on page 13.

Try tuning even if all previous fail, system may be just in some non typical state, like just after powering up the system or helium level may be very low. If this does not help, you need to contact the system administration or to tune manually to find out what is wrong.

If all channels are mostly out of lock (small negative bars), check that there is helium in the dewar. If not, inform the system administrator immediately to prevent system to warm up completely. If there are helium, try loading a known tuning file. If this does not help, manual tuning is needed.

If just some channels are noisy, try heating the channels. See “Heating sensors” on page 13.

---

### 4.2 Viewing noise history of a channel

---

If some particular channel is misbehaving in tuning, you can study the noise values of a channel in previous noise measurements, e.g. how the

noise evolved during the tuning process. To do this select one channel to be displayed.

Selecting a channel can be done in three ways:

- By entering the channel number into the channel number box of the operating point controls. The number should be the ordinal number, not the number in the sensor name. See Figure 2.1
- By inserting the channel name into the channel name box of the operating point controls. See Figure 2.1.
- By clicking the noise bar of the channel in the noise display with the left mouse button while pressing the **CTRL** key.

The display will now show the name of the channel and a curve that indicates the noise level at each noise measurement made during the session. You can scale the noise history display same way as the bar display. See “Noise display” on page 15.

To change back to view all channels:

1. Enter 0 into the channel number box or
2. Click anywhere in the display with right mouse button having the **CTRL** button simultaneously pressed down.

You can also view the previous operating point tuning values by clicking with the left mouse button any particular measurement time. The bias, offset, and gate values are shown in the information area. This is especially useful if the tuning has for some reason failed and the noise has been lower with some other parameters than the current ones. You can read the old parameters by clicking the noise history curve at the point where the noise was low and then write the tuning values into the operating point control area at the left top corner. This way you can easily get back the good values.

Another typical usage for reading old tuning values is to check that some abrupt change in noise is not due to change in tuning values but because of a change in the sensor or environment.

The Command menu contains buttons that can be used to show noise histories of all channels at the same time and to clear the history records.

---

### 4.3 Tuning selected channels

---

In some cases it may be useful to tune only some selected channels. This is possible by “locking” some channels. When channels are locked they are ignored in all automatic tuning operations. Locked channels are shown as black bars in the noise displays and their noise values are not taken into account when the average value shown on top of the display is calculated.



Channels can be locked by two methods:

- by clicking the noise bar in the display using the left mouse button while pressing the **SHIFT** key simultaneously.
- By using the “active channels” dialog, which can be popped up by selecting the menu button **Parameters > Active channels**.

The “active channels” dialog is shown in Figure 4.1. The upper part of the dialog contains a check box for each channel. The boxes are labeled with the number part of the channel names. When the check box is set, tuning is allowed for this particular channel. You can switch individual channels by clicking the box and then closing the dialog by pressing **OK** button.

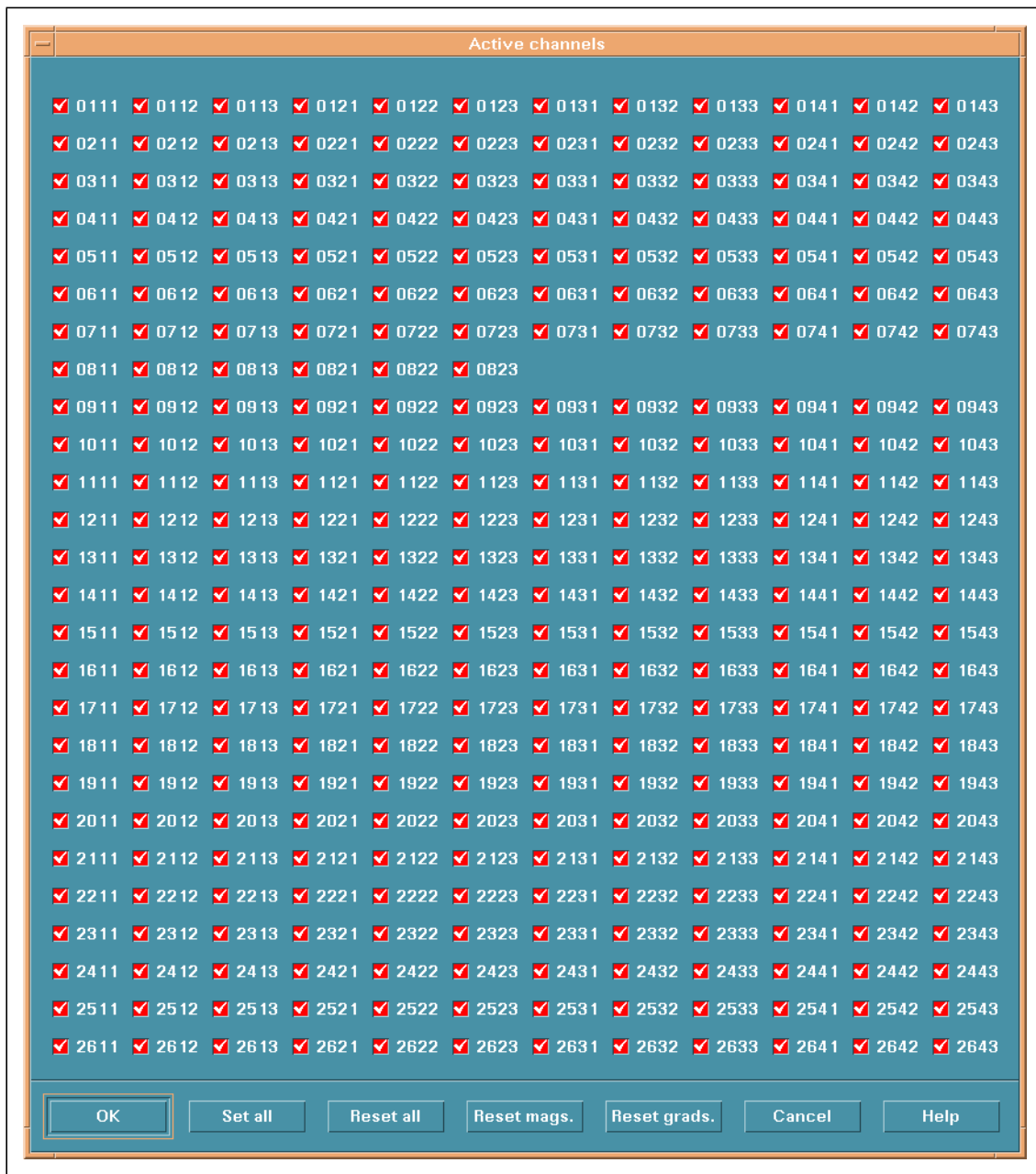

Figure 4.1

At the bottom of the dialog there are some extra buttons in addition to the standard ones. By using the, you can set or reset large set of channels easily.

The buttons that alter the selections are:

<b>Set All</b>	Activate all channels.
<b>Reset all</b>	Deactivate all channels
<b>Reset mags</b>	Deactivate all magnetometers
<b>Reset grads</b>	Deactivate all gradiometers

So if you want to tune only one particular channel, press **Reset all** button to deactivate all channels and then activate the channel you want to tune by clicking its activation button.

---

## CHAPTER 5 Description of the menus

---

This chapter contains descriptions of the menus as they appear in lowest expert level. For full menu descriptions see “Description of the menu” on page 61.

---

### 5.1 File Menu

---

The **File** menu contains commands that are related to saving and loading of the internal state of the program and the measurement device.

#### **Load tunings**

This button enables you to load magnetometer state from a file. The file must be in the tuner parameter format (.tnp). Using this command, only the state parameters are loaded, all the rest of the information in the file is discarded. See also “About saving and loading settings” on page 14.

#### **Save tunings**

This button saves all currently active parameters into a file. It also sets the “current” operating point information within the program to values being used at the saving time. See also “About saving and loading settings” on page 14.

#### **Preferences**

This button opens a dialog box that can be used to set preference information, like some colors and the expert level. Preference information is always saved when program exits.

#### **Exit**

Use this button to stop the program. A verification is required to really stop the program.

---

### 5.2 Parameters Menu

---

This menu contains buttons that pop up dialogs that enable the modification of parameters used in various tasks.

**Active channels**

This button pops up a dialog that allows you to set which channels are affected by the tuner. If a channel is not active, it is not modified. See “Tuning selected channels” on page 18.

---

## 5.3 Commands Menu

---

This menu contains buttons for various commands that can be executed.

**Reset electronics**

Pressing this button causes resetting of all active channels. See “Resetting channels” on page 13.

**Heat sensor**

Pressing this button heats the sensor element containing currently selected channel. See “Heating sensors” on page 13.

**Heat all sensors**

Pressing this button heats all sensor units. See “Heating sensors” on page 13.

**Show all histories**

Selecting this button will show a graph containing noise histories of all channels superimposed on top of each other. See “Viewing noise history of a channel” on page 17.

**Clear histories**

Clears the history records of all the channels. See “Viewing noise history of a channel” on page 17.

---

## 5.4 Search Menu

---

This menu contains buttons that allows you to find channels according to some characteristic feature of the channel. In order to make these searches to work, the particular characteristic of the channel must be first measured.

**Worst Noise**

Search the channel with largest white noise.

**Next**

Search next channel. This button performs an incremental search using the same criterion as the last search to find second, third etc. bad channel.

---

## 5.5 View Menu

---

This menu contains buttons that select what information is shown in the graphics area. This setting is also changed to a suitable default value when a job is selected from the Job menu, so it is not needed often.

### **Noise**

Select the white noise level to be shown on the graphics area.

### **Noise Histogram**

Select the white noise levels to be shown as a histogram.

---

## 5.6 Help Menu

---

The help menu contains currently only one button that displays the version and the linking time of the program.



# PART 2

## Sensor operation principles

---

---

This part describes the operation principles of a SQUID sensor and electronics. It also contains a detailed description how the sensors are tuned manually. Manual tuning is needed in the initial setup of the device and when the automatic tuning fails for some reason.

Reading of this chapter is recommended for all users who want to understand the operation of the device. Understanding of the operation is necessary for the maintenance personnel and when reading the third part describing the advanced features of the tuning program.





# Principles of SQUID operation

This chapter explains the operating principles of a SQUID sensor and readout electronics. It gives the necessary background information that is needed in manual tuning of the sensors.

## 6.1 Operation of a SQUID magnetometer

The Superconducting QUantum Interference Device (SQUID) is the only sensor with sufficient sensitivity for biomagnetic measurements. The SQUID is a transducer that converts magnetic flux into electric signal.

The basic structure of a SQUID magnetometer is illustrated in Figure 6.1. The external magnetic field is not sensed directly by the SQUID; rather, it is coupled to the SQUID detector by means of a flux transformer. The flux transformer consists of two coils: a pickup coil that gathers the flux, and a signal coil that couples it into the SQUID. This has the advantage of increasing the field sensitivity by increasing the effective sensor area (magnetic flux equals field times sensor area). Vectorview uses two kinds of pickup loops: magnetometers and gradiometers. Magnetometer loops are simple rectangular loops. Gradiometer loops comprise two rectangular coils side by side, wound in opposite sense. This arrangement is “near-sighted” which greatly improves the rejection of environmental magnetic noise.

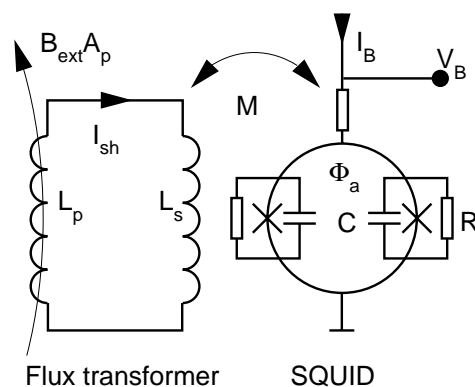
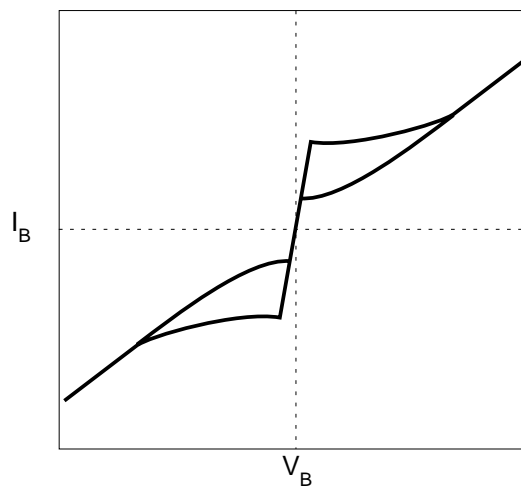

**Figure 6.1** Schematic of a SQUID sensor

The SQUID is formed out of a superconducting ring, interrupted by two weak links or so called Josephson junctions. Without these interruptions the external magnetic fields, such as those generated by the brain, would have no detectable effect on the superconducting ring. These links consist of a microscopical isolating layer that is thin enough to ensure that the

ring will maintain its superconducting properties, but only up to a certain limit.

When operating the SQUID, a small current (bias current) is fed through the SQUID ring and the voltage over the device is measured. When the current through the SQUID is small, no voltage appears because the ring is totally superconducting. Above a critical value (critical current) a voltage drop appears. The apparent critical current of the SQUID depends on the magnetic flux threading the ring. Thus, maintaining the bias current at a suitable level, a small change in the magnetic flux coupled from the external source via the flux transformer will change the point where the ring loses its superconductivity and voltage drop appears. This results in a modulation of the voltage as a function of magnetic field.



**Figure 6.2** Current-voltage characteristics of a SQUID

Another way is to fix the voltage (bias voltage) over the SQUID and measure the current through the device. Vectorview electronics uses this voltage-bias mode of operation. Figure 6.2 depicts the current vs. voltage characteristics of a typical SQUID sensor. The characteristics consist actually of a family of curves for each value of magnetic flux threading the ring. However, the dependence on the magnetic flux is periodic, and it is customary to plot only the extremum curves. As the magnetic flux through the ring changes, the shape of the current vs. voltage curve changes continuously between the two extrema. The period with which the behavior repeats itself is one flux quantum  $\Phi_0 = 2.07 \cdot 10^{-15} \text{ Wb}$ . The two extremal curves shown in Figure 6.2 thus correspond to magnetic flux values separated by  $\Phi_0/2$ .

Near the origin, the SQUID is in superconducting state and current can flow through without a voltage loss. In Vectorview, there is a deliberately added small series resistance which causes a finite slope near the origin as in Figure 6.2.

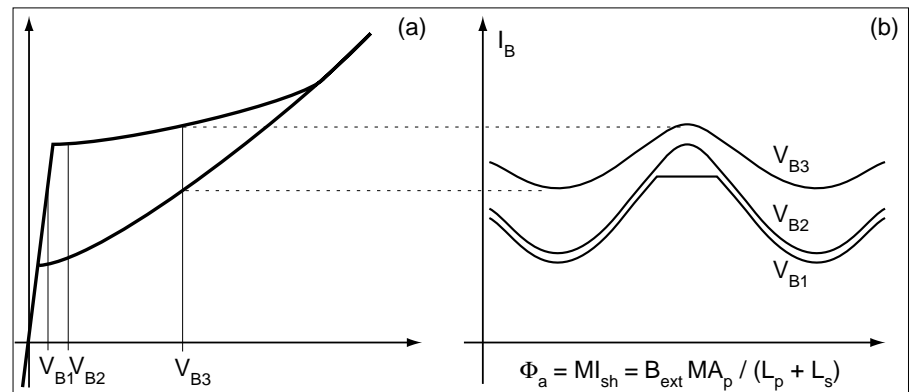

**Figure 6.3** a) Examples of voltage bias points on I-V curve. b) Flux-current characteristics at the example bias points.

If the bias voltage is set to level  $V_{B1}$  in Figure 6.3(a), the current through the SQUID varies as a function of magnetic flux as given by the lowest curve in Figure 6.3(b). The sensor remains partly in superconducting state; therefore, there is a plateau in the current vs. flux characteristics. At a bias voltage of  $V_{B2}$  the sensor is biased just above the superconducting state, and a maximum modulation depth appears, as seen from the middle curve of Figure 6.3(b). If the bias voltage is further increased to  $V_{B3}$ , the modulation depth decreases, finally tending to zero. At large bias voltages the SQUID looks like a resistor.

## 6.2 SQUID electronics of Vectorview

Figure 6.4 illustrates the principle of operation of the Vectorview readout electronics. The signal is coupled from pickup coil to the SQUID via flux transformer, as discussed in previous section. In addition, there is an auxiliary coil, a so-called feedback coil which is used by the readout electronics to couple various signals to the SQUID.

The bias voltage is set with the help of an operational amplifier which is also employed to amplify the SQUID signal. The operational amplifier tries to keep the voltage across its input terminals constant by feeding current via the feedback resistor back to the input. As a result, the voltage over the SQUID remains at a preset value of  $V_B$ , and the current through the feedback resistor which is directly proportional to the operational amplifier output voltage then is the actual output signal.

Even with the best operational amplifiers the noise of the amplifier exceeds that of the SQUID. Therefore, Vectorview employs a so-called amplifier noise cancellation circuit. The basic idea is to couple the SQUID voltage through a variable conductance, here a field-effect transistor (FET), and an auxiliary coil back to the SQUID magnetically. This positive feedback decreases the effect of the preamplifier voltage noise. By adjusting the gate voltage of the FET the strength of this coupling can be

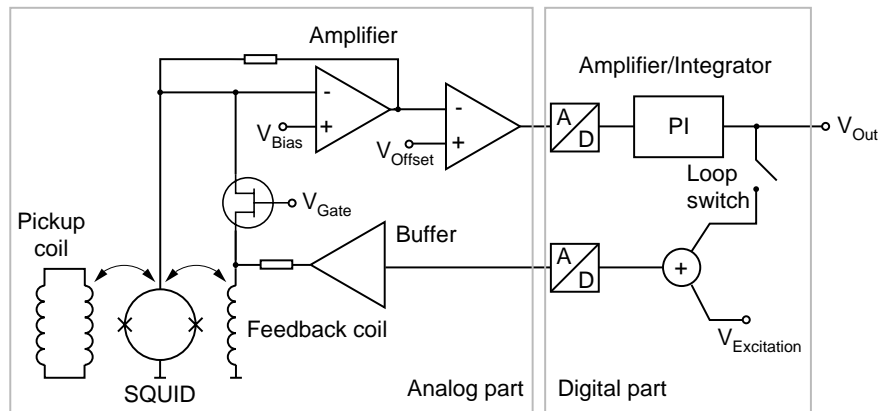

**Figure 6.4** SQUID electronics

adjusted: with large negative gate voltage the conductivity is low, and the effect of the amplifier noise cancellation circuit remains small. When the gate voltage is made less negative, the compensating effect increases and finally cancels the amplifier noise. If the gate voltage is further increased the feedback coupling becomes too large, leading to instability and increased noise.

Since the current vs. flux characteristics are periodic with respect to flux, the sign of the derivative  $(\partial V)/(\partial \Phi)$  may be either positive or negative. Therefore, the amplifier noise cancellation circuit only works where the derivative has a proper sign, say, on the falling slope. (The actual sign of the slope where amplifier noise cancellation is effective depends on how the feedback coil is arranged.) On the opposite slope, the noise is increased rather than decreased. The proper tuning of the gate voltage is discussed in more detail in section 6.3.

To linearize the periodic current vs. flux characteristics, a so-called flux-locked loop is employed. The output of the SQUID is integrated and fed back to the feedback coil. When the feedback loop switch (see Figure 6.4) is closed, a current proportional to the time integral of the SQUID output voltage is fed to the feedback coil. As a result, the point of operation along the current vs. flux characteristics changes and the corresponding current through the SQUID changes. A stable point is only reached if the input of the integrating amplifier reaches zero. Therefore, an offset is added to the current vs. flux characteristics to make the curve pass through zero line. The system then “locks” to the point of operation where the apparent output of the SQUID (containing the additional offset) is zero; any change in the input flux from the gradiometer causes a change in the feedback current that exactly compensates the input flux change. Thus, the feedback

current is a replica of the input flux. Since the SQUID with its periodic response is now operated as a null detector, the final output signal, a voltage directly proportional to the feedback current, is linear.

For tuning purposes, it is necessary to feed in external flux to see the current vs. flux characteristics. Therefore an external flux signal can be fed through the feedback coil.

In Vectorview the flux-locked loop is implemented using digital signal processors which allow accurate operation and plenty of flexibility. All loop characteristics, operating modes, and filters are digital and easy to control. Signal processors reside physically in the electronics cabinet by the shielded room. The analog part consists of preamplifiers and circuits that generate the bias, offset, and gate voltages. These are on top of the dewar. All the signals between the two parts are converted from analog regime to digital and vice versa on the signal processor boards.

The operation of both analog and digital parts are controlled by the real-time computers of the system. The program controlling the analog part is called Janitor, and the program controlling the signal processors and data stream to acquisition workstation is called Collector. Normally these programs are not used directly, but through either the acquisition program or the tuning program.

---

### 6.3 Optimal point of operation

---

The optimal point of operation of the SQUID is the combination of bias, offset and gate settings that gives the minimum noise. The noise depends on all those parameters.

Normally, the voltage bias that gives the maximum modulation depth also gives minimum noise. The current vs. flux characteristics should be above superconducting state everywhere (no visible plateaus). For stable operation, the adjustment should not be just on the edge but rather slightly above. In some rare cases it may happen that minimum noise is achieved at a higher bias; this is usually the case if the current vs. flux characteristics is not smooth. Then it may be necessary to adjust the bias higher. Note that the shape of the current vs. flux characteristics is also affected by the gate voltage setting. When in doubt, always set the gate voltage to value 150 to decouple the amplifier noise cancellation before trying to find a bias setting at which the current vs. flux characteristics looks smooth.

---

**Warning:** Do not adjust gate setting to values below 150 unless the optimum noise is achieved with a lower value. Some FET transistors may alter their characteristics with low bias voltages. This manifests as a shift in the optimal gate setting which relaxes in a couple of hours.

---

The offset should be set so that the current vs. flux characteristics curve crosses zero in order to be able to operate the flux-locked loop. The actual point of operation to which the system locks is determined by the point where the curve crosses zero line. The noise of the SQUID depends in general on the value of the input flux. It has been found experimentally, that for Vectorview SQUIDs the minimum noise is most often achieved for an offset setting where the zero level crosses the current vs. flux characteristics one-quarter above the minimum of the curve.

The gate voltage setting affects the amount of amplifier noise cancellation. It is set to a value where the noise is at minimum.

---

## CHAPTER 7 Manual tuning

This chapter deals with the manual tuning procedure. We assume here that the user is familiar to SQUID working principles (see “Principles of SQUID operation” on page 27) and to basic Tuner operation (see “Basic Usage” on page 3). The manual tuning can be done using two different programs and both are described here only as much as it is needed to perform the manual tuning.

---

### 7.1 Need for manual tuning

---

When the system is cooled down for the first time, a manual tuning must be performed for all channels. The tuning settings are strictly valid only for a certain SQUID sensor-electronics card pair. Therefore, if a SQUID sensor is changed or if an electronics card is changed, new settings must be searched manually. Note that each electronics card drives 12 SQUIDs; if a card is changed, all channels belonging to that card must be adjusted. After major service operations, e.g., warm up – cool down cycle, it is advisable to check the tuning settings by going through the manual tuning cycle.

If you encounter degraded performance, try first heating (see “Heating sensors” on page 13), then loading a previously loaded setting file that corresponds most closely to the actual Helium level (see “About saving and loading settings” on page 14). If that does not help, point of operation should be tuned manually.

---

### 7.2 Tools for manual tuning

---

Since Vectorview flux locked loop electronics are digital, all tuning displays are computer generated and no physical tools are needed. What is needed is a x-y -display to show the flux vs. current ( $I-\Phi$ ) characteristics, a display to show real time signal or noise level, and controls to alter the bias, offset, and gate settings of a SQUID. There are two tools for manual tuning. You can either use the SQUID tuning program in expert level 1, or Squiddler, which is a small controller dialog accessing the electronics settings directly. The SQUID tuning program provides more auxiliary functionality to ease the tuning, but the Squiddler works faster (has better response times) since it does not make any measurements. Squiddler is used in conjunction with the normal acquisition program to make the required measurements. The tuning program is used for both measuring and adjusting.

### 7.3 Measuring flux to current curves using Squiddler

---

The  $I-\Phi$  curves of a SQUID sensor can be measured using Squiddler and acquisition program. For the meaning of  $I-\Phi$  curve, see “Operation of a SQUID magnetometer” on page 27.

To measure I-Phi curves using Squiddler:

1. Start both acquisition program and the Squiddler program. See “*Data Acquisition User’s manual*”.
2. Press the **x-y** button at the lower part of the raw data display to show the x-y display.
3. Start acquisition. Default parameters are fine.
4. Set the measurement mode to tuning mode by selecting **Mode > Tune** from the Squiddler menu.
5. Select the channel to be viewed using Squiddler. You can either enter the name of the channel into the text field **Channel** or use the slider by the text field.

The  $I-\Phi$  curve should now be on the x-y display.

### 7.4 Measuring flux to current curves using Tuner

---

You can also use Tuner to measure the  $I-\Phi$  curves. To do this, you must be using expert level 1. To change the expert level see “Setting the expert level” on page 43.

To measure I-Phi curves using Tuner:

1. Select **Job > Manual tune** from the Tuner menu.
2. Press the “start button”.
3. You should now see a bar diagram showing the modulation depths of all channels. Select one particular channel to see the  $I-\Phi$  curve.
4. To stop the measurements, press the “stop button”.

The various options available in Tuner are described in more detail in Chapter 8. The information here should be enough to carry on the basic manual tuning.

### 7.5 Measuring noise level

---

Manual tuning process also requires an ability to measure the noise level of a sensor. Though the acquisition program does not provide this possibility explicitly, the tuning of the noise level can be made by judging the changes in noise level by eye, looking at the raw data display.



To measure the approximate noise level using Squiddler:

1. Select **Mode > Meas** from the Squiddler menu.
2. Use the navigation buttons in the raw data display to show a particular channel on the display.

To measure the noise level with the Tuner, see “Measuring the sensor noise level” on page 11. The right edge of the noise history trace shows the current noise level. You can also use the raw data display in a similar manner as when using Squiddler.

---

## 7.6 Manual tuning procedure

---

Manual tuning is a process to set the SQUID operating point parameters to optimal values. This section describes this process step by step using the measurement methods described in previous sections.

---

**Warning:** Do not adjust gate setting to values below 150 unless the optimum noise is achieved with a lower value. Some FET transistors may alter their characteristics with low bias voltages. This manifests as a shift in the optimal gate setting which relaxes in a couple of hours.

---

---

**Warning:** In some Vectorview systems pre-amplifiers are capable to deliver signal levels which saturate the inputs of DSP boards enough to cause them to “fold” the signals. If the signal is very noisy and changes to opposite direction than normally when bias or offset is adjusted, scan the whole bias/offset range to get the signal into normal regime again.

---

To tune a sensor manually:

1. Set the measurement system into tuning mode using either Squiddler or Tuner.
2. Choose the channel to be tuned.
3. Adjust the bias voltage to find the maximum modulation depth of the current vs. flux characteristics. The number in the bias setting (0...255) is proportional to the bias voltage. Use the mouse or up and down arrow keys to position the cursor to bias setting field. The value can then be entered by typing in a number followed by a return or by changing the setting one-by-one using the right arrow and left arrow keys.
  - If the system has been tuned earlier, start from the current bias and offset values. Otherwise set the offset voltage to a value near the middle (128). Adjust the bias until you find the point where the lower end of the current vs. flux characteristics curve shows a plateau like curve  $V_{B1}$  of Figure 7.1(a). Start the bias search from about 150 and decrease the value using the left arrow key until you

see the plateau. If you go down too much, the current vs. flux characteristics goes via zero and turns over, see Fig. Figure 7.1(b). Be sure to be on the right side.

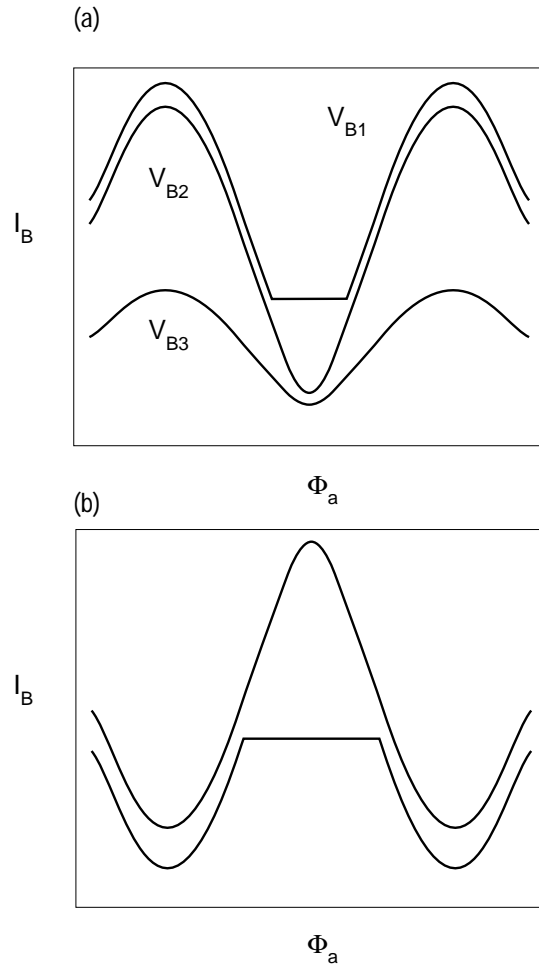

**Figure 7.1** Bias tuning

- Adjust the offset voltage so that the current vs. flux characteristics is approximately in the middle of the screen
  - From the point where the plateau on the bottom appears, increase the bias setting until it has completely disappeared, see curve  $V_{B2}$ . You may decrease the bias further by one or two units to ensure stability. The current vs. flux characteristics should look rather smooth now.
  - If the current vs. flux characteristics is not smooth, set the gate voltage to 150. If this does not remove irregularities, try increasing the bias setting, even with the expense of losing some modulation depth.
4. Adjust the gate voltage.

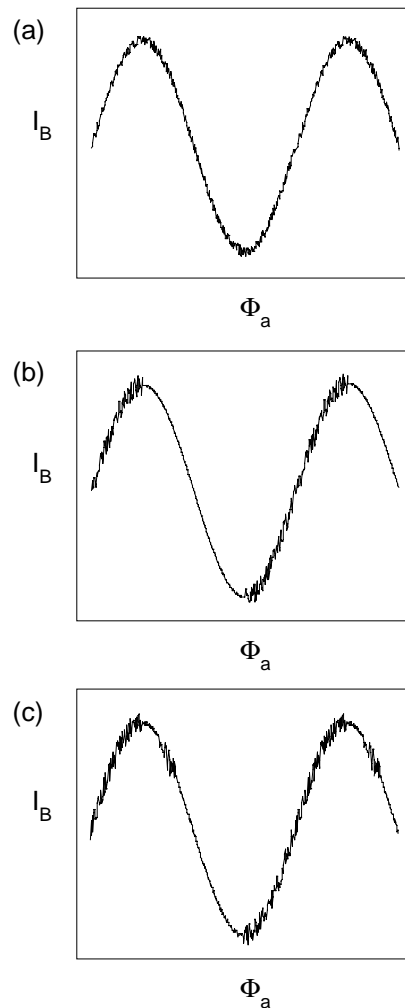

**Figure 7.2** Gate tuning

- If the system has been tuned earlier start from the current value of the gate setting. Otherwise start from 150. Increase the value by the right arrow key. The noise on the falling slope diminishes, see Figure 7.2(b), until an irregularity appears as in Figure 7.2(c). Stop increasing the gate at that point. In the actual SQUID, the noise might be difficult to distinguish on the 10V-scale; the appearance of a hump in the current vs. flux characteristics is a clear sign indicating that the gate voltage has been increased too much.
  - Decrease the gate voltage step-by-step back until the hump has completely disappeared and the current vs. flux characteristics looks again smooth
5. Adjust the offset voltage so that approximately one quarter of the current vs. flux characteristics is below the zero line and three quarters above it. See Figure 7.3 (c).
  6. Change Squiddler/Tuner settings to make a noise measurement. Now you should see a signal trace on the raw data display screen or the noise level trace of Tuner. The noise seen should be minimized by fine-tuning the gate and offset. At this point, you can either use automatic

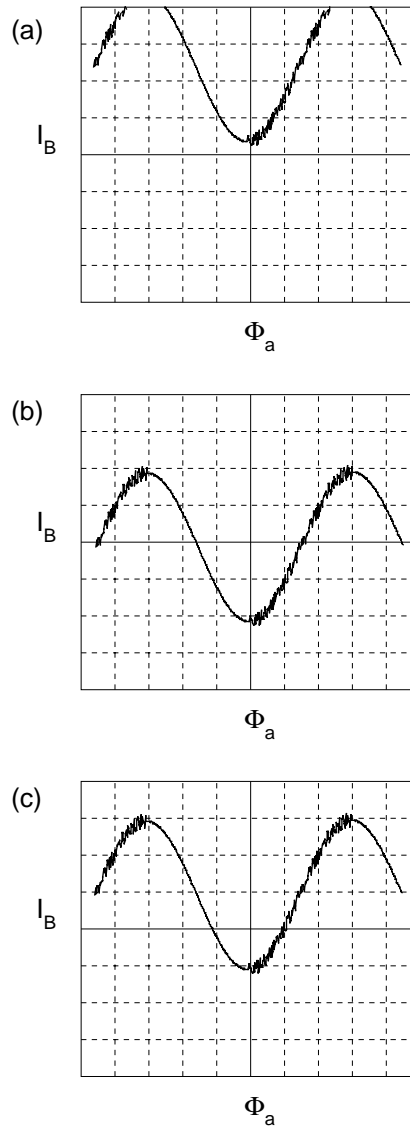

**Figure 7.3** Offset tuning

fine tuning (See “Fine tuning” on page 12.), or tune the noise level manually using the following instructions:

- Adjust the gate voltage by the arrow keys step by steps on both sides. Observe the noise amplitude and see whether it can be made smaller by adjusting the gate.
- If you are uncertain about the optimum, try the following technique: lower the gate voltage until you see the noise to increase clearly. Then go back by increasing the gate voltage until the extra noise is gone.
- Finally, try adjusting the offset a few steps on both sides to see whether the noise can be made smaller. If there is no clear change, leave the setting at its original value.
- If the signal shows extra white noise (evenly distributed) the gate probably needs adjustment; if the signal shows spikes, especially

with an unsymmetrical distribution, probably the offset needs readjustment

7. If the noise level is still higher than in other channels, check the current vs. flux characteristics again and try readjusting the bias (step 3).

---

## 7.7 Typical sensor problems

---

This section describes several types of sensor problems and the procedures how to deal with them.

Tuning the sensors in presence of strong disturbances, may cause the noise level measurements to be affected by them. This appears as abnormally high average noise level on magnetometer channels. This external noise masks the sensor noise, and makes the tuning difficult and inaccurate. In such conditions, SSP should be used in noise measurements. See Section 11.8 on page 59 and Section 8.6 on page 47.

If the current v.s. flux curve shows hysteresis, this is most often due to trapped flux in the sensor. To cure the problem, heat the sensor. If this does not help, try repeating the heating a couple of times, or try changing the heating time temporarily to 2 seconds.

Sometimes the current v.s. flux curve is tilted, that is, one end of the curve is higher than the other as if the zero line was tilted. This is most likely due to moisture in the preamplifier connector on the top flange of the dewar. To fix this problem, the connectors must be dried. Tuning is not likely to remove the problem. This kind of phenomenon may also be result of other types of hardware failures.

If the real time signals (on raw data display) in the normal measurement mode show jumping between two levels (also called “popcorn noise”), most likely reason for this is trapped flux. To cure the problem, heat the sensor.

If the real time signals show low frequency drifting in a small set of channels, this may due to oxygen snow in the dewar. If this is the case, only way to remove the problem is to heat the whole dewar. This can be performed only by skilled maintenance personnel. Note that this kind of phenomenon may also rise due to bad SSP vectors. Check carefully the channels both with and without the SSP and compare the behavior to good channels.



# PART 3

## Advanced features

---

---

This part describes the advanced features of the SQUID tuning program. These include measuring various characteristics of the sensors and manual and automatic tuning of several parameters. Features described here are intended for maintenance personnel and require that the user expert level is set to 1. For the basic automatic fine tuning process for everyday use, see Part 1.

The basic knowledge on SQUID operating principles and Vectorview electronics given in Part 2 is assumed. For a general description of manual tuning refer to Part 2.





---

## CHAPTER 8 Basic measurements

The tuning program is a versatile tool that can be used measure several characteristics of a SQUID sensor. These measurements are used with suitable adjustment routines to perform various optimization and characterization operations. This chapter describes the basic measurements that can be made.

The basic measurements available are the following:

### **I/Phi**

Measure flux to current transfer function of the SQUIDs. This measurement is used to view the SQUID characteristics, to measure modulation depths for detecting flux trapped sensors, and to measure I-V curves of the SQUIDs.

### **Noise**

Measure the white noise level of the sensors. This provides a fast measurement of the white noise levels. Also the dc and line frequency level of disturbances are measured. These can be viewed manually or used in automatic noise level tuning.

### **FFT**

Measure the spectrum of the sensor signal. This gives more detailed information about the noise compared to the “Noise” measurement, but is slower. Spectra can be shown on a display and noise values in selected bands can be printed.

### **Signal**

Measure a sample of the time trace of the sensor signal. This measurement can be used to get a sample of signal to visually examine its quality.

---

## 8.1 Setting the expert level

---

In order to use features described in this part, the “expert level” must be set to 1. The setting defaults to zero but it is saved in the preferences of the user so that once it has been changed it is kept from session to session.

To change the expert level setting:

1. Select **File > Preferences** from the menu. A dialog box containing all the values regarded as preferences is popped up.

2. Change the entry in the text field **expertLevel** and press **RETURN**. After changing the level new entries should appear in to the preferences dialog. Also some new menus will appear.
3. Close the dialog by pressing **Close**.

The rest of the parameters in preferences settings dialog are explained in Appendix B.

---

## 8.2 Selecting and running jobs

---

Before starting an operation you need to select what to do. You can select the operation from the **Job** menu. The jobs are described in more detail in the following sections.

The “jobs” available are:

<b>I/Phi</b>	Measure flux vs. current curves.
<b>Noise</b>	Measure white noise levels.
<b>FFT</b>	Measure spectra.
<b>Signal</b>	Measure signal trace.
<b>Tune</b>	Tune noise.
<b>Tune (fine)</b>	Fine tune noise.
<b>Tune (gate)</b>	Tune noise adjusting only gate values.
<b>Tune (offs)</b>	Tune offset setting.
<b>Manual tune</b>	Measure I/Phi curves fast to allow manual tuning.
<b>Meas derivatives</b>	Measure parameter derivatives at operating point.

To run a measurement, select it from the **Job** menu, unless it is already selected. The text on the “start button” changes according to the job so that you can identify the currently selected job. To start a measurement press the “start button”, to stop it, press the “stop button”.

There are two kinds of jobs. Some of them are continuous; they continue until they are explicitly stopped. Others are one time jobs which are started and they automatically stop when they are ready.

The acquisition system runs in three different states during the usage of Tuner. It can be either idle, suspended, or active. When the program starts, the acquisition is idle (unless somebody else is performing a measurement). When a job is initiated the acquisition system is started and it becomes active. When a job stops, the acquisition is suspended, not stopped. This means that the front end (Collector program) is actually collecting data continuously, but it is not send to the clients like Tuner. The benefit of this arrangement is that if the measurement parameters are not changed, a new measurement can be started without delays. The stop button has a dual action. When a measurement is running, pressing it stops the current operation and suspends the acquisition. The label on the “stop

button” is changed to “Stop collector”. Another press will then stop the acquisition and release the acquisition front end.

The measurement system must be idle to start new measurements using the normal acquisition program. It is not necessary (but recommend) to exit the Tuner in order to use acquisition, but the measurement must be stopped into idle mode.

---

### 8.3 Measurement parameters

---

Each measurement or job has a set of parameters associated to it. These affect the exact details how some operation is performed. Typical examples are sampling frequencies and number of averages taken. The default values are adjusted to be good for normal usage, but some times it is useful to be able to adjust them. In addition to measurement parameters, program uses also various other parameters for defining operating points, preferences etc.

The following sections describing a job also describe the associated parameters. For a complete list of all parameters see Appendix B.

The parameters can be adjusted using dialogs that can be accessed through the **Parameters** menu. They are classified using two classification schemes: parameter sets and classes. The parameter set defines which parameter dialog is used to edit them, and the class defines the general context in which the parameter is used. Typical sets are e.g. “Noise measurements” and “Tuning settings”, containing the parameters affecting the noise measurements, and fine tuning. Typical classes are e.g “Measurement parameters” and “State parameters”, giving instructions to measurement routines and describing operating point settings.

To change a parameter value:

1. Select the button corresponding the parameter set of the parameter in the **Parameters** menu.
2. Edit the value in the text box by the parameter name and press **RETURN**.
3. Close the parameter box.

Closing the box is not necessary since the values are changed immediately when **RETURN** is pressed.

## 8.4 View modes

In most cases the result of a measurement can be displayed in several formats, or different aspects of the result can be shown. For each measurement/job there are two principal displays. One showing all channels and another showing one specific channel. Typically the data shown for all sensors are somehow compressed.

To select the overview (all channels), set the active channel to 0. To show some particular channel, select the channel either by clicking the bar representing it or by using the operating point controls. See “Noise display” on page 15.

Specific measurement results can be selected for viewing from the **View** menu. The displays that are associated to each measurement mode are listed in the description of each mode.

## 8.5 I-Phi measurement

The I-Phi job measures the flux versus current characteristics of all sensors. It can average several measurements and the data is arranged so that it is possible to estimate factors like feedback voltage corresponding one  $\Phi_o$ , modulation depth etc.

If these characteristics are needed for manual tuning purposes, use “Manual tune” instead. It performs the same measurement without any averaging showing the raw x-y data. The basic I-Phi job is rarely used manually, however the measurement is used as a building block in several other jobs, so that adjusting the parameters in “I-Phi measurements” does affect several other jobs.

The parameters affecting the I-Phi measurements are shown in table Table 8.1.

Parameter	Type	Description
AveLength	integer	Number of x bins in x-y trace curves used in averages.
NumAverages	integer	Number of averages taken.
TuneSfreq	float	Sampling frequency used. [Hz]
FuncAmp	float	Excitation amplitude. [V]
FuncFreq	float	Excitation frequency. [V]

**Table 8.1** Parameters affecting I-Phi measurements

The I-Phi measurement results can be displayed using following view modes:

### **I-Phi curve**

This mode shows the  $I-\Phi$  curve of the sensor SQUID when a single channel is selected. The overview mode (all channels) shows a bar diagram where the top and bottom of the bar show the maximum and minimum values of the  $I-\Phi$  curve. This view is useful to check that the offset settings of all channels are proper. Each bar should cross the zero line so that about one third of the bar is below the line.

### **Modulation (abs)**

This mode shows the  $I-\Phi$  curves of the sensors same way as the I-Phi mode, except that in the overview display all bars have been shifted to start from the zero line, so that they display the modulation depth clearly.

### **Modulation**

This mode is similar to “Modulation (abs)” except that the modulation depths have been normalized using the nominal modulation depth at the nominal operating point. For setting / resetting the nominal operating point, see “Operating point parameters” on page 53. In this view all bars should have height of exactly 1.0. Any change in modulation depth is easily noticeable. This mode is useful for checking the presence of flux trapped SQUIDs and shifts from the nominal operating point.

---

## **8.6 Noise measurement**

---

Another basic operation is to measure the white noise level of the sensors. This measurement gives a reasonably good and robust estimate of the noise level with a quick measurement. The measurement band is in high frequencies, so that normal external disturbances do not affect it much. As a further refinement, line frequency disturbances are filtered away from the data.

This mode is a tool that can be used to check quickly the quality of the data on all channels. It is also a building block used in all noise optimization jobs. In addition to white noise level, this job measures also the dc

level and line frequency disturbance amplitude on each channel. The parameters affecting the noise measurements are shown in table Table 8.2.

Parameter	Type	Description
NoiseHpf	float	High pass filter corner frequency. [Hz]
NoiseLpf	float	Low pass filter corner frequency. [Hz]
NoiseSfreq	float	Sampling frequency. [Hz]
NoiseNAve	integer	Number of averages.
NoiseSsp	0 or 1	Is SSP used?
IgnoreAfterReset	integer	How many buffers to ignore after reset.
GoodEnough	float	Noise level regarded as good enough.

**Table 8.2** Parameters affecting noise measurements

The noise measurement results can be displayed using following view modes:

#### **Noise**

This mode shows the sensor white noise level. Overview shows a bar for each channel showing the noise. Single channel view shows the noise history (results of previous measurements within the session).

#### **Noise histogram**

This mode is similar to “Noise” mode, except that the overview shows a noise histogram.

#### **DC levels**

This mode shows the dc levels of the channels.

#### **DC level histogram**

This mode shows the DC levels as a histogram.

#### **Line freq. levels**

This mode shows the level of the fundamental frequency of the line frequency.

#### **Line freq. level histogram**

This mode shows the line frequency levels as a histogram.

## 8.7 FFT measurement

The job “FFT” is for measuring power spectra of the channels. This can be used to examine the external disturbances and noise characteristics in more detail compared to the “Noise” measurement. The spectrum estimation uses a Hanning window and non-overlapping averaging.

The parameters affecting the FFT measurements are shown in table below.

Parameter	Type	Description
TimeBufSize	integer	Time buffer length. [samples]
FFTsize	integer	FFT transformation length. [samples]
FFTthpf	float	High pass filter setting. [Hz]
FFTlpf	float	Low pass filter setting. [Hz]
FFTsfreq	float	Sampling frequency. [Hz]
FFTaverages	integer	Number of averages.
FFTssp	0 or 1	Is SSP used?
FFTlowStart	float	Start of low freq. estimation range. [Hz]
FFTlowEnd	float	End of low freq. estimation range. [Hz]
FFTwhiteStart	float	Start of white noise estimation range.[Hz]
FFTwhiteEnd	float	End of white noise estimation range. [Hz]

**Table 8.3** Parameters affecting FFT measurements

The Time buffer size defines the length of the time trace that is actually measured. From the beginning of each time trace, FFTsize samples are taken and transformed into Spectral noise density per unit band (1/Hz). The length of the time buffer should be at least the length of the Fourier transform. In order to get better statistics, several spectra can be averaged. The number of averages is controlled by parameter FFTaverages. It is possible to apply SSP noise reduction to the data before calculating the FFT in order to diminish the contribution of external disturbances.

The last four parameters in Table 8.3 define two bands, one for numerical estimation of the low frequency noise and another for estimating the white noise level. The noise power in these bands can be shown as a bar diagram.

The FFT measurement results can be displayed using following view modes:

### **FFT**

This mode shows the sensor/environment noise level. Overview shows three sets of bars superposed on top of each other. Bars from front to back: aliasing noise level (white), white noise level (red), and low frequency noise level (black). All noises are displayed in RMS (per  $\sqrt{\text{Hz}}$ ). Single channel view shows the RMS spectrum of the selected channel.

---

## **8.8 Signal**

---

This job measures a sample of time signal trace. The length of the trace is controlled by the parameter TimeBufSize in parameter set “FFT measurements”. When this job is selected, the single channel view shows the time trace of that particular channel. The overview mode shows the last FFT measurement result, if any.



# Tuning procedures

The tuning program is capable to perform several automatic tuning operations in addition to manual tuning. This chapter describes the tuning operations available.

All the tuning operations are based on the measurements described in the previous chapter. They typically employ a loop containing a measurement and adjusting of some parameters.

The tuning procedures available are the following:

**Tune**

Optimize the white noise level by adjusting bias, offset, and gate settings.

**Tune (fine)**

Same as “Tune”, but with smaller steps in adjustments.

**Tune (gate)**

Same as “Tune”, but only the gate value is adjusted.

**Tune (offs)**

Adjusts the offset setting so that the zero line in the I- $\Phi$  plot crosses the curve at specified level.

---

## 9.1 Noise level based tuning

---

To optimize the noise level of the sensors, Tuner provides procedures to automatically tune the operating point parameters. All three routines are similar. They differ only on adjusted parameters and the size of the adjustment steps.

The basic job “Tune” is provided for general purpose everyday tuning. A detailed description of its usage is given in part “Basic Usage” starting on page 3. It measures the white noise level, adjusts one parameter, and then measures again. If the new noise level was lower than the previous, the new settings are accepted. The sequence of adjustment is such that the gate value is optimized first starting with rather large steps that then shorten quite quickly. After the initial rounds on gate, the routine enters into a loop optimizing sequentially bias, offset and gate values with a step size of 2.

The “Tune(fine)” works similarly optimizing all parameters using step of one unit.

The “Tune(gate)” mode adjusts only gate values. Bias and offset values are left intact.

---

## 9.2 Tuning based on characteristics

---

The tuning mode “Tune(off)” differs considerably from the tuning modes described in the previous section. Instead of measuring the noise level, it measures the  $I-\Phi$  curve, and adjusts the offset so that the curve meets a predefined criterion. The “fraction” parameter describing the level at which the  $I-\Phi$  curve crosses the zero level is adjusted so that it matches the value defined for the nominal operating point. Only the offset settings are changed.

---

## 9.3 Manual tuning

---

To perform manual tuning, the tuning program provides a special measurement mode “Manual tune”. This is optimized for manual operation so that the measurement speed and update frequency are maximized. No adjustments are made automatically. You can alter the settings using the controls in the upper left corner of the user interface.

## CHAPTER 10 Measuring characteristics

This chapter describes how to measure several characteristic curves of a SQUID sensor. These measurements are based on the basic measurements described in Chapter 8. Typically a curve is measured by repeating a measurement with different parameter settings and picking up some particular aspects of the measurement result.

Measuring the  $I-\Phi$  curve is regarded as a basic measurements and is described in “I-Phi measurement” on page 46.

### 10.1 Operating point parameters

The operating point of a SQUID is defined by the bias, offset, and gate settings as described in Chapter 6. In addition to these settings, the characteristics of the SQUID at some particular operating point can be described by a set of parameters like modulation depth etc. Some of these parameters are needed by the tuning routines, some are useful in checking the proper operation of the sensor.

The program has two concepts for the operating point: the current operating point and the nominal operating point. The first one is naturally the current state of the sensors, the second one is the “correct” operating point that was either loaded from a state file, or the state which prevailed when a state file was saved (which ever has occurred last). The current state can be set as the “nominal” operating point also by selecting **Commands > Snapshot** from the menus.

One can examine the estimated parameters of each channel using “Channel info” dialog available through **View > Channel info** menu button. For each parameter two values are shown; one for the current state (from last measurement performed, if any) and for the nominal operating point (from the state last loaded or saved from/to a parameter file).

The parameters shown in the channel info dialog are:

<b>Channel</b>	Running channel number of the sensor.
<b>Bias</b>	Bias setting.
<b>Offs</b>	Offset setting.
<b>Gate</b>	Gate setting.
<b>Modulation</b>	Modulation depth (volts in input).
<b>Phi0</b>	Flux quantum size (“volts” in excitation line).
<b>Fraction</b>	Where $I-\Phi$ curve crosses the zero line (0% = lower edge, 100% = higher edge).
<b>dV/dB</b>	Voltage change per bias adjustment unit in $I-\Phi$ mode.
<b>dV/dO</b>	Voltage change per offset adjustment unit in $I-\Phi$ mode.
<b>Bias drift</b>	(Not used)

**Offs drift** (Not used)  
**He level** helium level.

Operating point settings, modulation depth, and fraction are updated in every I- $\Phi$  measurement. Helium level is automatically checked when the program starts. The flux quantum sizes can be estimated after a I- $\Phi$  measurement by selecting **Commands > Estimate phi0** from the menus. The derivative information must be measured with a separate routine described in next section.

---

## 10.2 Measuring derivative information

---

To measure the operating point derivative information:

1. Check that the current operating point is correct.
2. Check that all I- $\Phi$  traces are on the screen, and none of them is very near saturation (near highest or lowest signal level available).
3. Select **Job > Meas. derivatives** from the menus.
4. Press the “start button” and wait until the measurement is finished.

This measurement calculates also estimates for the flux quantum sizes. Note that the dV/dB value is not needed in any of the current optimization of characterization routines, and that the dV/dO value is independent of the operating point, so in many cases the operating point does not matter, as long as the signals do not saturate during the measurement.

---

## 10.3 Measuring and using current-voltage characteristics

---

To measure the I-V curve of the SQUIDS:

1. Check that derivative information is available, If not measure it (See Section 10.2).
2. Select **Job > I-V curve** from the menus.
3. Press the “start button” and wait until the measurement stops.

The I-V curves are displayed using three curves: two showing the extreme values, and one showing the modulation depth. A cursor cross hair shows the current operating point in the graph. The curves are available until the end of the session.

One usage for the I-V curves is a quick initial tuning. When the I-V curves have been measured, one can set the operating point of the SQUID by clicking a point in the graph with the left mouse button, having both **SHIFT** and **CTRL** buttons pressed.

---

## 10.4 Measuring gate curves

---

To measure the noise as a function of the gate value setting (with fixed bias and offset settings), select **Job > Scan gate** from the menus and wait until the measurement ends.

## CHAPTER 11 Miscellaneous

This chapter describes some miscellaneous operations related to searching channels, settings files, and Janitor program.

### 11.1 Searching channels

---

The program offers several search routines to search channels for some particular feature.

Following searches can be performed from the **Search** menu:

- Worst offset** Find channel whose  $I-\Phi$  curve crosses zero line at a level that differs most from the value defined for the current working point.
- Worst noise** Find channel having largest white noise level.
- Weird Phi0** Find channel whose flux quantum size differs most from the other channels.
- Next** Find next worst channel. Before this command one of the first three commands must be issued to select which parameter should be searched.

### 11.2 Loading and saving in special cases

---

In addition to normal saving and loading of tuning parameters, there are two options: loading of parameters of a single channel, and saving and loading of some selected parameters only.

The normal **File > Save tunings** operation saves all parameters, except the preference parameters. The normal **File > Load tunings** loads only operating point parameters, all other parameters are neglected. Therefore one can for example check from a tuning file, what kind of measurement settings were used, when the file was made, but these measurement settings do not affect the current settings when the file is loaded.

Using the command **File > Save > Load current channel only** one can load only the operating point parameters of the current channel (channel selected to be viewed).

To save or load only some selected parameters to all of the channels, use menu commands **File > Load > Load selected params** or **File > Save > Save selected params**. These commands pop up a special file selection dialog button which has a toggle button for each parameter group. By selecting and deselecting these buttons, one can choose which parameter groups are saved or loaded.

---

### 11.3 Marking broken channels

---

Some channels can be marked broken in the start-up files. This causes that these channels will automatically behave as if they were marked inactive from the active channels dialog. See “Tuning selected channels” on page 18. The flag indicating a broken channel can be toggled using menu command **Commands > Toggle broken status**. The change of the status flag is temporary and affects only the current session, unless the settings are saved into the start-up file. See Section 11.5.

---

### 11.4 Reverting operating points

---

The program has two options to undo tuning settings. It is possible either to return to the state which prevailed when the program was started, or to the “nominal” operating point.

To revert settings to state at program start-up time:

1. Select **File > Revert to start-up state** from the menus.

To revert to the previous nominal point of operation:

1. Select **File > Revert to previous o.p.** from the menus.

---

### 11.5 Creating start-up files

---

To make the tuner run easily and properly, one should have two start-up files properly set. When the program is started, it loads four files in following order:

1. `/neuro/dacq/tuning/system.tnp` (start-up script may alter this name).
2. `/neuro/dacq/tuning/static.tnp` (may be altered in the previous file).
3. “Current operating point file” deduced from the helium level.
4. `~/tuneprefs` containing the personal preference settings.

The first one is intended for fixed measurement parameters etc. and it gives default values for all parameters defined in the file. It should not be altered unless there is a need to permanently change the default values. Usually the file delivered with the system should be ok.

The second one is a file that should contain values for “static parameters”, that is parameters that are assumed to be independent from the operating point, but which vary from device to device. From this file only parameters in classes “static” and “state” are loaded, so it may contain also other parameters which are neglected. See Appendix B.

The “static” file needs to be generated for each system after any larger maintenance operation, like changing an electronics board or a sensor. Before saving the file, the system should be tuned, and the derivative information should be measured. See “Measuring derivative information” on page 54. The file can be saved normally using the **File > Save settings** menu command.

The third file loaded is deduced from the current helium level, and is assumed to contain the nominal operating point settings. Only the operating point settings are loaded. However, these settings are not activated automatically, so that the current operating point is not changed. If the nominal and current operating point do differ, one can get to the nominal one either by reloading the file explicitly or by **File > Revert to previous op** menu command. This file should be saved after tuning the system. See “About saving and loading settings” on page 14.

---

**Note:** Loading of the operating point parameters works differently during the initial loading and when the parameters are loaded explicitly by issuing a menu command. During the initial loading the settings of the magnetometer are not changed. Only the variables defining the “correct” operating point are changed. When the settings are loaded explicitly, the new values are sent also to the magnetometer.

---

The last file loaded is the preferences file, which contains the personal preferences settings for each user. Only the parameters in class “preferences” are loaded. The preferences are saved automatically each time the program is exited.

---

## 11.6 Updating the power-up settings

---

The power-up settings have been initially set at factory to values that should enable reasonable operation of the system. Normally, you should not change these values. Only if there is some major service operation which results in a substantial change of the tuning parameters, the power-up settings should be updated.

To update the power-up settings file:

1. Using a Unix shell, connect to the Janitor program at the real time computers (assuming that the server runs on computer called “kaptah3”): `telnet kaptah3 janitor`.
2. Give the password: `pass <password>`
3. Issue a dump command: `dump current`.
4. Make a backup copy of a file “/neuro/dacq/setup/janitor.powerup”. Copy the newly created setup file from “/opt/HP-RT/tmp/janitor.dump” to “/neuro/dacq/setup/janitor.powerup”.



---

## 11.7 Synchronizing Janitor

---

If the pre-amplifier power is brought down, the registers on the boards lose their contents. Currently this situation is not automatically noticed by the Janitor (electronics software driver running at the real time computers). Janitor can be forced to update all values in the electronics by giving a “sync” command. This can be easily achieved by selecting the **Commands > Sync Janitor** command from the menus. In normal situation this command just refreshes all registers in the dewar-top electronics, so it should not cause any harm to issue the command.

---

## 11.8 Using SSP

---

Noise reduction based on signal space projection (SSP) can be used in several measurement mode. Modes that allow the noise reduction have a parameter xxxSSP, where xxx depends on the measurement. The need of using the noise reduction depends on case to case. The normal tuning can be performed without SSP, unless the environment is very noisy. On the other hand, spectra calculated for the magnetometers are severely affected by the external noise, unless SSP is used.



---

## CHAPTER 12 Description of the menus

---

This chapter gives reference information about all menu buttons. It contains only a very brief description of the actions and possibly a reference to a more detailed description. This section applies when the expert level is set to 1.

---

### 12.1 File Menu

---

The file menu contains commands that are related to saving and loading of the internal state of the program and the measurement device.

#### **Load tunings**

This button enables you to load magnetometer state from a file. The file must be in the tuner format (.tnp). Using this command, only the state parameters are loaded, all the rest of the information in the file is discarded. If you need to load some other information, use **Load > Load selected params** button. See “About saving and loading settings” on page 14.

#### **Save tunings**

This button saves all currently active parameters into a file. It also sets the “current” operating point information within the program to values being used at the saving time. See “About saving and loading settings” on page 14.

#### **Revert to previous o.p.**

This button returns the magnetometer tuning state to the “current” tuning state. This state reflects the state of the magnetometer at the time when the program was started, or the state specified in the parameter file last loaded or saved. See “Reverting operating points” on page 57.

#### **Revert to start-up state**

This button returns the magnetometer tuning state to the state that was prevailing when the tuner program was started. It undoes all changes made by the tuning program. See “Reverting operating points” on page 57.

**Load > Current channel only**

Load settings of the currently selected channel only. See “Loading and saving in special cases” on page 56.

**Load > Load selected params**

Load some selected parameter sets to all channels. See “Loading and saving in special cases” on page 56.

**Save > Save selected params**

Save some selected parameter groups only. See “Loading and saving in special cases” on page 56.

**Preferences**

This button opens a dialog box that can be used to set preference information, like some colors and the expert level. Preference information is always saved when program exits. For description of the preference parameters, see Appendix B.

**Exit**

Use this button to stop the program. A verification is required to really stop the program. See “Ending a session” on page 10.

---

## 12.2 Job Menu

---

This menu contains buttons that define the operation that should be performed. The job is not executed immediately. These buttons only select which job will be run when the “start button” is pressed. For more detailed descriptions of the jobs see Chapter 8 and Chapter 9.

**I/Phi**

Select measurement of flux to current characteristics.

**Noise**

Select white noise measurement. This gives less information, but is faster than a measurement of noise spectrum. It also provides the level of line frequency disturbance and the dc-levels of all the channels.

**FFT**

Select FFT measurement that gives the spectrum of the signals. This gives information about the noise as a function of frequency, but it is slower than a measurement of white noise only.

**Signal**

Measure signal samples.

**Tune**

Select automatic tuning of all operating point parameters. This version uses larger steps than the fine tuning (below). Faster than the fine tuning but not as robust.

**Tune (fine)**

Select the automatic tuning of all operating point parameters using small steps.

**Tune(gate)**

Select automating tuning of gate settings only.

**Tune(off)**

Select automatic adjustment of offset values.

**Manual Tune**

Select manual tuning mode.

**Meas. derivatives**

Select measurement of operating point derivative information.

**Meas I-V curve**

Select measurement of current versus voltage curves.

**Scan gate**

Select measurement of noise versus gate value.

---

## 12.3 Parameters Menu

---

This menu contains buttons that pop up various dialogs that enable the modification of parameters used in various tasks. The parameters are described briefly in Appendix B.

**Active channels**

This button pops up a dialog that allows you to set the channels that are affected by the tuner. If a channel is not active, it is not modified, and it set to a “passive” state to minimize its effect on other channels. See “Tuning selected channels” on page 18.

**System Parameters**

Popup an editor for system parameters.

**I-Phi measurements**

Popup an editor for I-Phi measurement parameters. See “I-Phi measurement” on page 46.

**Noise measurements**

Popup an editor for noise measurement parameters. See “Noise measurement” on page 47.

**FFT measurements**

Popup an editor for spectrum measurement parameters. See “FFT measurement” on page 49.

**Tuning settings**

Popup an editor for tuning parameters.

**Bias scan**

Popup an editor for bias scan parameters. See “Measuring and using current-voltage characteristics” on page 54.

**Gate scan**

Popup an editor for gate scan parameters. See “Measuring gate curves” on page 55.

---

## 12.4 Commands Menu

---

This menu contains buttons for various commands that can be executed.

**Reset electronics**

Pressing this button causes resetting of all active channels. See “Resetting channels” on page 13.

**Heat sensor**

Heat a single sensor. See “Heating sensors” on page 13.

**Heat all sensors**

Heat all sensors. See “Heating sensors” on page 13.

**Sync janitor**

Synchronize Janitor state. See “Synchronizing Janitor” on page 59.

**Snapshot**

Mark current state as the nominal operating point. See “Operating point parameters” on page 53.

**Estimate phi0**

Estimate flux quantum sizes from a I-Phi measurement results. See “Operating point parameters” on page 53.

**Show all noise histories**

Selecting this button will show the a graph containing noise histories of all channels superimposed on top of each other. See “Viewing noise history of a channel” on page 17.

**Clear histories**

Clears the history records of all the channels. See “Viewing noise history of a channel” on page 17.

**Toggle broken status**

Toggle status flag used for marking broken channels. See “Marking broken channels” on page 57.

---

## 12.5 Search Menu

---

This menu contains buttons that allows you to find channels according to some characteristic feature of the channel. In order to make these searches to work, the particular characteristic of the channel must be first measured. See “Searching channels” on page 56.

**Worst offset**

Find channel with largest error in “fraction” parameter.

**Worst Noise**

Search the channel with largest white noise.

**Weird Phi0**

Search the channel whose measured flux quantum differs most from the average.

**Next**

Search next channel. This button performs an incremental search using the same criterion as the last search (activated by one of the buttons described above) to find second, third etc. bad channel.

---

## 12.6 View Menu

---

This menu contains buttons that select the information shown on the graphics area. This setting is also changed to a default value when a job is selected from the Job menu, so it is not often needed.

**Channel Info**

This button pops up a dialog box that shows miscellaneous information about the current settings of the selected channel. See “Operating point parameters” on page 53.

**Raw trace**

Show the I-Phi data time trace.

**I-Phi curve**

Select the I-Phi curve to be shown on the graphics area. Curve is shown only if a I-Phi measurement has been performed during the session. See “I-Phi measurement” on page 46.

**Modulation**

Select the overview of relative modulation depths. See “I-Phi measurement” on page 46.

**Modulation (abs)**

Select the overview of absolute modulation depths. See “I-Phi measurement” on page 46.

**I-V curve**

Show the last measured I-V curve. See “Measuring and using current-voltage characteristics” on page 54.

**Noise**

Select the white noise level to be shown on the graphics area. See “Measuring the sensor noise level” on page 11.

**Noise histogram**

Select the white noise level histogram to be shown. See “Measuring the sensor noise level” on page 11.

**FFT**

Select the spectrum of the signal on the selected channel, or a overview of noises on all of the channels when channel zero is selected. See “FFT measurement” on page 49.

**Signal**

Select viewing of signal samples. See “Signal” on page 50.

**Gate curve**

Select viewing of noise versus gate setting curve. See “Measuring gate curves” on page 55.

**DC levels**

Select the graph showing dc-levels of the channels.

**DC level histogram**

Select the graph showing the dc-levels as a histogram.

**Line freq. levels**

Select the line frequency levels to be shown on the graphics area.

**Line freq. level histogram**

Select the graph showing line frequency levels as a histogram.



**Bias history**

Show history of bias value settings.

**Offset history**

Show history of offset value settings.

**Gate history**

Show history of gate value settings.

---

## 12.7 Help Menu

---

The help menu contains only one button that displays the version and the linking time of the program.

## APPENDIX A Command line options

This appendix describes the command line arguments and options of the tuning program.

Command syntax: `tune_vv <options>`

Command line options:

**-nolock**

Ignore lock files.

**-expert <number>**

Set the expert level of the user.

**-default <measurement>**

Set the default measurement mode. The valid values for the measurements with this option are: `tune`, `fine-tune`, `noise`, `i-phi`, `manual-tune`, `fft`, `gate`, `bias`, `offs`, `modu`, `signal`.

**-defs <filename>**

Define the name of the file containing the system parameters (default values).

**-static <filename>**

Define the name of the file containing the “static” parameters.

**-load <filename>**

Define the name of the state file to load in start-up.

**-site <filename>**

Define the name string describing the measurement site.

**-device <filename>**

Define the name string describing the device.

The valid values for the measurements with the `-default` option are:

`tune`, `fine-tune`, `noise`, `i-phi`, `manual-tune`, `fft`, `gate`, `bias`, `offs`, `modu`, `signal`.

## APPENDIX B Parameters

This appendix lists all parameters that can occur in a tuner parameter (.tnp) file. The parameters are arranged by their *parameter set*. Each set contain parameters that are (or would be) displayed in same dialog box. The *class* of a parameter is a tag that is used to group functionally similar parameters together. Parameters can for example be loaded per class basis, and e.g. class preferences is saved to a special file. Parameter name is the name used in the setup files. If the type name contains brackets [] after the name, this means that the parameter is a vector (typically one value for each channel). If the type contain braces {} the type is a set of the base type objects

The system parameters contain parameters that describe the structure of the measurement system and its environment. The parameters are shown in Table B.2.

class	parameter name	type	description
system	SysType	string	Type of the device
system	LineFrequency	float	Power line frequency of the site [Hz]
system	OVLlevel	float	Overload voltage level [V]
system	UseHeNames	integer	Use helium level in state file names?
system	HeLevels	integer{ }	List of helium levels used [%]
system	HeLevelLog	string	Name of the helium level log file
system	HeatingTime	float	How long to heat a sensor [s]
system	JanitorService	string	Janitor service name
system	JanitorBoot	string	janitor boot file name
system	CurrentPar	string	Directory for current parameter settings
system	HistoryDir	string	Directory for history files
system	ReferenceIV	string	Reference I-V
system	NoiseLog	string	Noise log file name
system	AuxCollVar	string	Auxiliary collector variable to be sent
system	ReferenceCh	integer	X-signal name

**Table B.1** System Parameters

The I-Phi parameters contain parameters that are related to I-Phi measurements. The parameters are shown in Table B.2.

class	parameter name	type	description
measurement	AveLength	integer	Number of x bins in x-y trace curves
measurement	NumAverages	integer	Number of averages in I-Phi measurements
measurement	TuneSfreq	float	Sampling frequency used in I-Phi measurements [Hz]
measurement	FuncAmp	float	Function generator amplitude [V]
measurement	FuncFreq	float	Function generator frequency [Hz]
measurement	WuFuInterval	integer	(reserved)

**Table B.2** I-Phi measurement parameters

The noise measurement parameters describe how to make a white noise measurement. The parameters are described in Table B.3.

class	parameter name	type	description
measurement	NoiseHpf	float	High pass filter used [Hz]
measurement	NoiseLpf	float	Low pass filter to be used [Hz]
measurement	NoiseSfreq	float	Sampling frequency to be used [Hz]
measurement	NoiseNAve	integer	Number of averages taken
measurement	NoiseSsp	integer	Is SSP used? [0 or 1]
measurement	IgnoreAfterReset	integer	How many buffers to ignore after reset
measurement	GoodEnough	float	Level below which the tuning is stopped

**Table B.3** Noise measurement parameters

The FFT parameters describe how the spectral calculations are performed. The parameters are listed in Table B.4.

class	parameter name	type	description
measurement	TimeBufSize	integer	Time buffer length [s]
measurement	FFTsize	integer	Length of the FFT transforms [samples]
measurement	FFTthpf	float	High pass filter used in FFT meas [Hz]

**Table B.4** FFT measurement parameters

class	parameter name	type	
measurement	FFTlpf	float	Low pass filter used in FFT meas [Hz]
measurement	FFTsfreq	float	Sampling frequency used in FFT meas [Hz]
measurement	FFTaverages	integer	Number of averages in spectra
measurement	FFTssp	integer	is SSP used in spectra calculation?
measurement	FFTlowStart	float	Start of low frequency interval [Hz]
measurement	FFTlowEnd	float	End of the low frequency interval [Hz]
measurement	FFTwhiteStart	float	Start of the white noise interval [Hz]
measurement	FFTwhiteEnd	float	End of the white noise interval [Hz]

**Table B.4** FFT measurement parameters

The tuning setting gives parameters that affect the offset value tuning. The parameters are listed in Table B.5

class	parameter name	type	description
measurement	Accuracy	integer	Required accuracy needed to stop [relative]
measurement	SettlingTime	integer	Length of the settling time after parameter changes [s]
measurement	LogCh	integer	Channel to be logged for testing

**Table B.5** Tuning settings

The bias scan settings affect the measurement of I-V curves.

class	parameter name	type	description
measurement	BiasScanStep	integer	Step size in bias scans
measurement	BiasScanInitialWait	integer	Settling time in the beginning [s]
measurement	BiasScanSettlingTime	integer	Settling time between measurements [s]
measurement	IVPlotBottomScale	float	Lower y-bound for I-V plots
measurement	IVPlotTopScale	float	Higher y-bound for I-V plots

**Table B.6** Bias scan

The gate scan parameters affect the measurements of noise versus gate setting curves.

class	parameter name	type	description
measurement	GateScanStart	integer	Start value for gate scans
measurement	GateScanStop	integer	End value for gate scans
measurement	GateScanStep	integer	Step size in gate scans
measurement	GateScanInitialWait	integer	Settling time in the beginning of the scan [s]
measurement	GateScanSettlingTime	integer	Settling time between measurements.
measurement	GateFork	integer	(reserved)

**Table B.7** Gate scan parameters

The operating point parameters define the nominal operating point and some sensor features at that point.

class	parameter name	type	description
state	OpHeLevel	integer	Helium level at the operating point
state	OpBias	integer[]	Bias setting at the operating point
state	OpOffs	integer[]	Offset setting at the operating point
state	OpGate	integer[]	Gate setting at the operating point
state	OpFract	float[]	I-Phi curve “fraction” at the o.p.
state	OpBiasDrift	float[]	(reserved)
state	OpOffsDrift	float[]	(reserved)

**Table B.8** operating point parameters

The static parameters define sensor characteristics, that are independent of the operation point.

class	parameter name	type	description
static	OpBtoV	float[]	Bias current change per setting unit
static	OpOtoV	float[]	Offset current change per setting unit
static	GateLow	integer[]	(reserved)
static	GateHigh	integer[]	(reserved)
static	OpMod	float[]	Modulation depth at o.p.

**Table B.9** Static parameters

class	parameter name	type	description
static	OpPhi0	float[]	Flux quantum size of a channel
static	OpNoise	float[]	Noise at the operating point
static	BrokenCh	integer[]	Is the channel broken?

**Table B.9** Static parameters

The preference parameters define values that are saved separately for each user. Color names defined for the X-window system are used as values of the color settings. A complete list of these names can be found from file `/usr/lib/X11/rgb.txt`.

class	parameter name	type	description
preference	TraceColor	string	Color used in curves
preference	BgTraceColor	string	Background trace color
preference	TextColor	string	Text color
preference	HistogramColor	string	Histogram boundary color
preference	LowFreqColor	string	Low frequency histogram fill color
preference	BandColor	string	White noise color for gradiometers.
preference	BandColor2	string	White noise color for magnetometers
preference	AliasedColor	string	Aliased noise color for histograms
preference	LockedColor	string	Histogram color for locked channels
preference	IgnoredColor	string	Histogram color for ignored channels
preference	ReadyColor	string	Histogram color for ready channels
preference	CursorColor	string	Cursor color
preference	NoiseNBins	integer	How many bins in noise histograms
preference	NoiseBinWidth	float	Bin width in noise histograms
preference	DCNBins	integer	How many bins in DC-level histograms
preference	DCBinWidth	float	Bin width in DC-level histograms
preference	LineNBins	integer	How many bins in line frequency histograms
preference	LineBinWidth	float	Bin width in line frequency histograms
preference	expertLevel	integer	Current expert level

**Table B.10** Preferences

Scaling parameters are used to preserve the display scales from one session to another.

class	parameter name	type	description
preference	DispScaleTrace	float	I-Phi curve scale
preference	DispOffsTrace	float	I-Phi curve offset
preference	DispScaleNoise	float	Noise plot scale
preference	DispOffsNoise	float	Noise plot offset
preference	DispScaleFFT	float	FFT plot scale
preference	DispOffsFFT	float	FFT plot offset
preference	DispScaleSign	float	Signal plot scale
preference	DispOffsSign	float	Signal plot offset

**Table B.11** Scales

Testing parameters are used only in internal test mode, not in actual use.

class	parameter name	type	description
testing	TestMode	integer	(reserved)
testing	TestOffset	float	(reserved)
testing	TestNoise	float	(reserved)
testing	TestLfNoise	float	(reserved)
testing	TestAmp	float	(reserved)
testing	TestSine	integer	(reserved)

**Table B.12** Testing parameters

The curve matching parameters are currently not used. They are defined for compatibility reasons.

class	parameter name	type	description
measurement	CurveMatchDelta	integer	(reserved)
measurement	CurveMatchLimit	float	(reserved)
measurement	CurveMatchMaxTry	integer	(reserved)
testing	CurveMatchVerbose	integer	(reserved)

**Table B.13** Curve match parameters



The obsolete parameters are defined to make the program backward compatible with old parameter files. They are not used by the program.

class	parameter name	type	description
obsolete	VErrorNBins	integer	(obsolete)
obsolete	VErrorBinWidth	float	(obsolete)
obsolete	MarkerStyle	integer	(obsolete)
obsolete	TuneBand	float	(obsolete)
obsolete	Npoles	integer	(obsolete)
obsolete	Step	integer	(obsolete)
obsolete	SpectrumLen	integer	(obsolete)

**Table B.14** Obsolete parameters

## APPENDIX C **Revision history**

This appendix describes changes made both to the manual and the program.

This manual applies to program `tune_vv` version 3.0.x which is a tuning program for Elekta Neuromag, Vectorview and Neuromag System devices. The program was developed from program `tune` version 2.0 which is used with Neuromag-122 systems. Due to such historical reasons the first release of `tune_vv` is numbered 3.0 rather than 1.0.

This is the second edition of the manual. Only difference from the first edition is that the company name and logo have been updated.

# Index

## A

Acquisition modes 44

## B

Beginning a session 9

Bias

current 28

setting 53

voltage 28, 29

Broken channels 57

## C

Channel info 53

Controlling displays 15

## E

Electronics

description 29

Exiting program 10

Expert level 1

setting of 43

## F

FFT measurements 49

File selection box

using 6

Flux locked loop 30, 31

Flux quantum 28

## G

Gate

setting 53

voltage 29, 32

Gradiometer 27

## H

Heating sensors 13

Help

online 10

Histogram

changing bin width 16

Histograms

changing resolution 16

viewing noise level 16

## I

I-Phi measurement 46

I-V characteristics 28

I-V curve 54

## L

Loading

settings 14, 56

Locking channels 19

## M

Magnetometer 27

Main window 10

Manual tuning 33, 35

Measurement modes 43

Measurement parameters 45

Measuring

characteristics 53

derivative information 54

flux quantum size 54

gate curves 55

I-Phi curves with Squiddler 34

I-Phi curves with Tuner 34

I-V curve 54, 59

noise level 47

Noise level with Squiddler 34

signal samples 50

spectra 49

white noise level 11, 17

Menu

Command 22

File 21

Help 23

Parameters 21, 45

Search 22

View 23

## Menus

using 5

## Modulation depth

explanation 28

**N**

## Noise cancellation

of the electronics 29

## Noise history 17

**O**

## Offset

setting 53

voltage 32

## Operating point 31, 53

parameters of 53

reverting 57

**P**

## Parameter class 45

## Parameter set 45

## Parameters

measurement 45

of FFT measurement 49

of I-Phi measurement 46

of noise measurement 48

## Point of operation. See Operating point

## Power-up settings 58

## Preferences 21

**R**

## Resetting channels 13

## Reverting operating points 57

**S**

## Saving

settings 14, 15, 56, 58

## Searching 56

## Selecting

channels to be shown 18

job 44

view of all channels 18

## Sensor operation 27

## Setting

expert level 43

## Showing

noise level as histogram 16

## Snapshot 53

**SQUID**

operation 27

**SSP**

and sensor problems 39

how to use 59

## Start button 9

## Starting

measurement 44

program 9

## Starting program 9

## Start-up files 57

## Status area 10

## Stop button 9

## Stopping program 10

**T**

## Text fields

using 5

## Troubleshooting 17

## Tuning

manually 35, 52

offset level 52

procedures 51

selected channels 18

white noise level 12, 51

**V**

## View modes 46

**W**

## Workspace 10

---

# List of procedures

- To change a parameter value: 45
- To change back to view all channels: 18
- To change the expert level setting: 43
- To heat a single sensor that contains a particular channel: 14
- To heat all the sensors: 14
- To load tuning settings into tuner and magnetometer: 14
- To measure I-Phi curves using Squiddler: 34
- To measure I-Phi curves using Tuner: 34
- To measure the approximate noise level using Squiddler: 35
- To measure the I-V curve of the SQUIDs: 54
- To measure the operating point derivative information: 54
- To measure white noise levels using Tuner: 11
- To reset all channels: 13
- To revert settings to state at program start-up time: 57
- To revert to the previous nominal point of operation: 57
- To save tuning settings into a file: 15
- To tune a sensor manually: 35
- To tune sensors automatically: 12
- To update the power-up settings file: 58